

reliable ^ professional ^ achievable



2 Materials Handling

2014 edition

www.lifting.com.au



Materials Handling

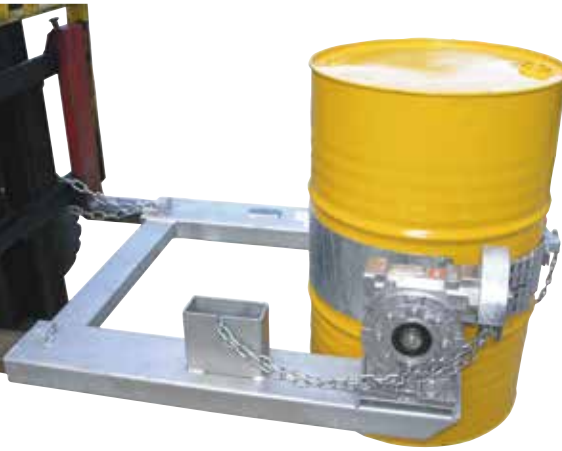

2

Safely hoisting and handling materials is crucial in any workplace. Robertsons only supply the highest quality products from leading brands, ensuring only the most efficient and secure products for use.

From chain and lever blocks to trolleys, hoists and winches supplied by leading manufacturers our full product range suits commercial, industrial and underground mining applications.

Chain & Lever Blocks	49
BEAVER 3G Industrial Manual Chain Lever Blocks	49
BEAVER 3G Industrial Chain Blocks	51
BEAVER 3G-V Industrial Lever Blocks	55
BEAVER 3G-V Industrial Chain Blocks With Safety Overload Clutch	57
PACIFIC Vital Chain Blocks	59
PWB Anchor M3 Chain Blocks	62
Trolleys & Clamps	63
Push & Geared Girder Trolleys	64
Pipe Trolleys & Girder Clamps	68
Hoists	73
Electric Chain Hoists & Trolleys	73
Permanent Magnet Lifters	85
Pneumatic (Air) Hoists	87
Winches	95
Electric Winches	95
Air Winches	100
Hand Winches	101
Digital Load Cells	104
Materials Handling Equipment:	105
Horizontal & Vertical Plate Clamps	105
Hand Operated Sheave Blocks	107
Heavy Duty Snatch Blocks	108
Gunnebo Snatch Blocks	109
Wire Rope Hoists	110
Concrete Clutches	111
Lifting Tongs & Clamps	112
Pipe lifters	114
Hand Pallet Trucks & Trolleys	115
Manufactured & Engineered Product	120
Forklift Attachments	120
Goods Cages	126 & 133
Pallet Hooks	129
Work Cages	130
Storage Cages & Gas Cylinder Storage	133 & 134
Spreader Beams, Bars & Systems	136

Chain & Lever Blocks



3G Industrial Manual Chain Lever Blocks

Model: 3G Capacities: 2500kg to 6 tonne

The 3G Industrial Manual Chain Lever Blocks have many features including the following:

Features

- › Heavy duty, available in 250kg to 6 tonne capacity.
- › **Colour coded to international lifting standards.**
- › A versatile lifting and tensioning device widely used in rigging, construction and mining.
- › Can be used in any direction, (must be in a straight line).
- › Includes a chain guide fitted, to stop the load from jumping out of the pockets on the load sprocket.
- › All 3G Industrial Chain Lever Block mechanism and gears are enclosed in a robust, all steel compact shell.
- › The load chain is Grade 80 Alloy Steel, black finish, heat treated, calibrated and marked according to Australian Standard AS1418.2.
- › All gears are fitted with industrial roller bearings.
- › The short arm lever and the gear ratio allows minimum effort to raise maximum load with maximum security.
- › The top and bottom hooks come complete with cast latches.
- › Top and bottom hooks are fitted with ball bearings to allow rotation under load.
- › Ergonomic design to ensure easy and convenient handling by hand.
- › Machined and heat treated gears, offering better durability and longer life cycle.
- › Each 3G Industrial Manual Chain Lever Block is operationally tested to its rated capacity and supplied with a test certificate, relating to its stamped identification side plate.
- › 'ID' plates and rivets supplied in stainless steel to avoid dangerous sparking, making them ideal for underground mining.
- › A comprehensive range of spare parts are available & Robertsons can provide full repair facilities and re-testing to NATA specifications.



Chain & Lever Blocks

3G Industrial Manual Chain Lever Blocks



Complies to AS1418.2.

Colour Coded to Match International Lifting Standards.

Product Code		504025	504050M	504075M	504150M	504300M	504600M
Rated Capacity kg		250	500	750	1500	3000	6000
Colour Code		Silver	White	White	Violet	Yellow	Brown
Standard Lift	(m)	1	1.5	1.5	1.5	1.5	1.5
Test Load	(Kn)	3.125	7.3	11	22	44.1	73.5
Headroom	H (mm)	245	3054	303	265	485	600
Effort on lever to lift full load	(N)	260	340	196	206	324	343
No. of chain falls	-	1	1	1	1	1	2
Diameter of load chain	(mm)	4	5	6	7	10	10
Length of lever handle	D (mm)	160	288	290	410	410	410
Dimensions	A (mm)	87	110	139	174	200	200
Dimensions	B (mm)	66	80	84	108	115	115
Dimensions	C (mm)	65	122	153	160	185	230
Dimensions	E (mm)	20	23	26	31	40	45
Weight	(kg)	2.13	4.5	7	11	20	30

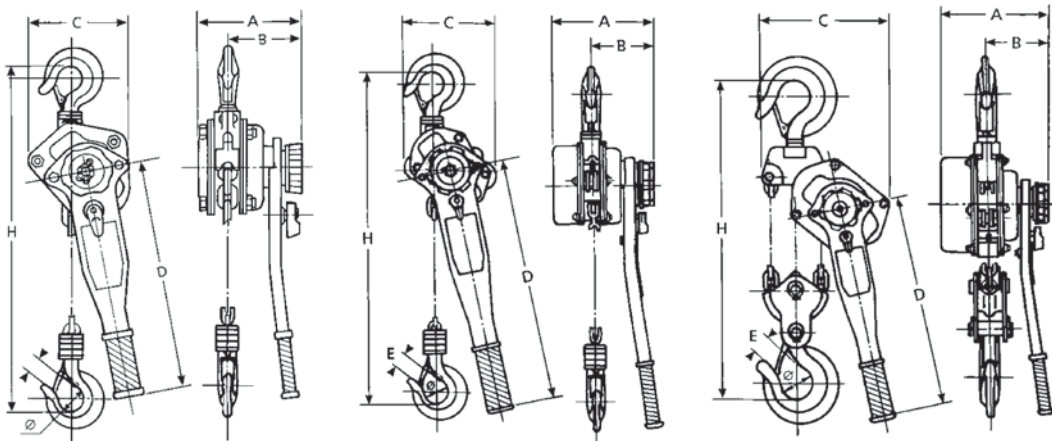

Chain & Lever Blocks

3G Industrial Chain Blocks

Model: 3G Capacities: 500kg to 3 tonne

The 3G Industrial Chain Blocks are designed for use on monorails, jib fixed installations and for maintenance use. They are to be used for vertical lifts only. If they are side loaded or used horizontally, jamming of the load chain and damage to the blocks may occur.

Features

- › Heavy duty, available in 500kg to 9 tonne capacity.
- › **Colour Coded To International Lifting Standards.**
- › Improved reinforced side covers, made from heavy duty steel to ensure full protection of the vital gears, shafts and bearings.
- › Load chain is Grade 80 Alloy Steel, black finish, heat treated, calibrated and marked according to Australian Standard AS1418.2.
- › All 3G Industrial Chain Block gears are fitted with industrial roller bearings.
- › Strong and engineer designed ratchet gears ensure maximum performance and security.
- › Machined and heat treated gears, offering better durability and longer life cycle.
- › Superior Weston type friction braking system that works with load pressure incorporating twin high strength synchronised pawls for additional safety – ensuring no free wheeling and a longer life.
- › Top and bottom hooks fitted with cast latches and ball bearings (allows rotation under load).
- › Every 3G Industrial Chain Block is operationally tested to its rated capacity and supplied with a test certificate, relating to its stamped identification side plate.
- › 'ID' plates and rivets are supplied in stainless steel in order to avoid dangerous sparking, making them ideal for underground mining.
- › A comprehensive range of spare parts is available, and Robertsons can provide full repair facilities and re-testing to NATA specifications.



Chain & Lever Blocks



3G Industrial Chain Blocks

Complies to AS1418.2.

Colour Coded to Match International Lifting Standards.

Product Code		500053M	500056M	500103M	500106M	500203M	500206M	500303M	500306M
Rated Capacity (kg)		500	500	1000	1000	2000	2000	3000	3000
Colour Code		White	White	Violet	Violet	Green	Green	Yellow	Red
Standard lift (m)		3	6	3	6	3	6	3	6
Falls of chain		1	1	1	1	1	1	2	2
Efforts to lift full load (kg)		21	21	33	33	36	36	39	39
Net weight (kg)		8	13	11	17	25	35	26	37
Hand chain overhauled to lift load one metre		32	32	39	39	77	77	154	154
Load chain diameter (mm)		5	5	6	6	10	10	8	8
Dimensions	A (Headroom) (mm)	290	290	340	340	450	450	500	500
Dimensions	B (Width) (mm)	142	142	170	170	240	240	205	205
Dimensions	C (Depth) (mm)	114	114	135	135	128	128	155	155
Dimensions	D (Diameter) (mm)	128	128	150	150	218	218	185	185
Dimensions	Hook opening (upper) (mm)	23	23	28	28	35	35	39	39
Dimensions	Hook opening (lower) (mm)	23	23	28	28	35	35	39	39

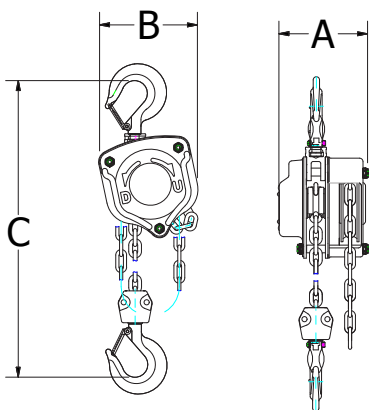

500 kg, 1 Tonne & 2 Tonne

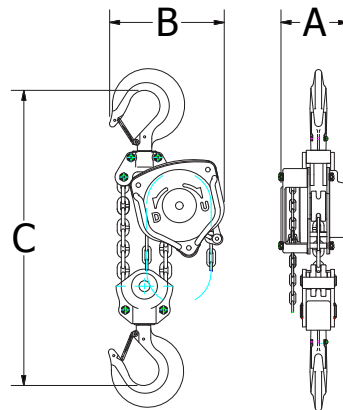

3 Tonne & 5 Tonne



Chain & Lever Blocks

3G Industrial Chain Blocks



Complies to AS1418.2.

Colour Coded to Match International Lifting Standards.

Product Code		500503M	500506M	500603M	500606M	500703M	500706M	500806M
Rated Capacity		5000	5000	10000	10000	20000	20000	30000
Colour Code		Red	Red	Orange	Orange	Orange	Orange	Orange
Standard lift (m)		3	6	3	6	3	6	6
Falls of chain		1	2	2	4	8	8	12
Efforts to lift full load (kg)		21	42	42	45	45	45	49
Net weight (kg)		39	56	78	125	122	252	491
Hand chain overhauled to lift load one metre		32	154	154	308	2x308	2x308	2x465
Load chain diameter (mm)		5	10	10	10	10	10	10
Dimensions	A (Headroom) (mm)	620	620	840	840	1060	1060	1500
Dimensions	B (Width) (mm)	240	240	240	240	240	240	705
Dimensions	C (Depth) (mm)	178	178	178	178	210	210	485
Dimensions	D (Diameter) (mm)	218	218	218	218	218	218	263
Dimensions	Hook opening (upper) (mm)	45	45	57	57	75	75	75
Dimensions	Hook opening (lower) (mm)	45	45	75	75	75	75	75

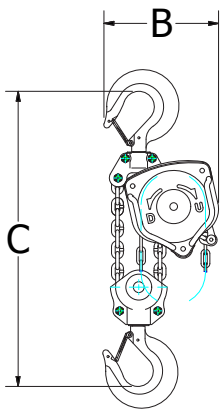

3 Tonne & 5 Tonne

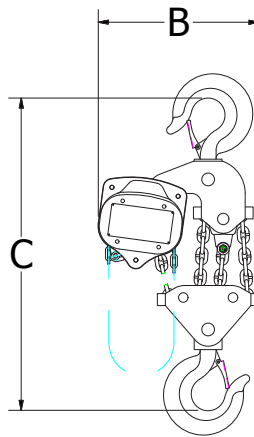

10 Tonne

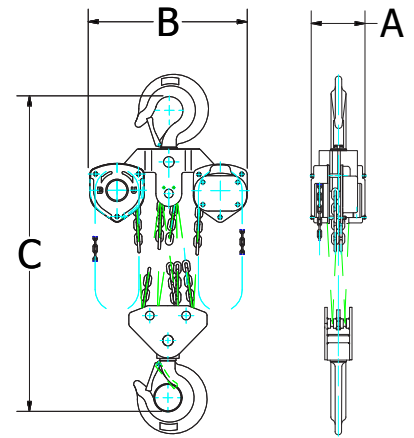

Chain & Lever Blocks

3G Industrial Manual Chain Blocks

Complies to AS1418.2

Product Code	500153	500156
Rated Capacity (kg)	1500	1500
Lift height (m)	3	3
Colour	Orange	Orange
Load Chain size (mm)	8x24	8x24
Falls of chain	1	1
Efforts to lift full load (kg)	39	39
Net Weight (kg)	18	26
Hand chain overhauled to lift load one metre	77	77
Load chain diameter (mm)	8	8
A (mm)	400	400
B (mm)	205	205
C (mm)	155	155
D (mm)	185	185
Hook opening (upper) (mm)	31	31
Hook opening (lower) (mm)	31	31



Beaver 3G Industrial Manual Chain Blocks – Black Powder Coated

Complies to AS1418.2

Product Code	500053MB	500056MB	500103MB	500106MB	
Rated Capacity (kg)	500	500	1000	1000	
Colour Code	Black	Black	Black	Black	
Standard Lift (m)	3	6	3	6	
Falls of Chain	1	1	1	1	
Efforts to lift full load (kg)	21	21	33	36	
Net Weight (kg)	8			25	
Hand chain overhauled to lift load one metre	32	32	39	77	
Load Chain diameter (mm)	5	5	6	10	
Dimensions	A (Headroom) (mm)	290	290	340	450
Dimensions	B (Width) (mm)	142	142	170	240
Dimensions	C (Depth) (mm)	114	114	135	128
Dimensions	D (Diameter) (mm)	128	128	150	218
Dimensions	Hook opening (upper) (mm)	23	23	28	39
Dimensions	Hook opening (lower) (mm)	23	23	28	39



Chain & Lever Blocks



LIFTALL 3G-V Industrial Lever Blocks

with Safety Overload Clutch (Limiter)

Model: 3G-V Capacities : 750KG to 9 tonne

Our range of Liftall 3G-V Industrial Lever Blocks include built-in safety overload clutch (limiter) technology, meaning greater work safety when lifting or pulling. This range of Lever Blocks has been carefully developed to comply with Australian Standards.

Features

- › Heavy duty, available up to 9 tonne capacity, the 3G-V Industrial Lever Block is designed for a variety of applications in mining, heavy industry, major construction works and off shore exploration.
- › The 3G-V Industrial Lever Block has all the features of the 3G lever blocks, with additional advantages.
- › The load chain is Grade 80 Alloy Steel, black finish, heat treated, calibrated and marked according to Australian standard AS1418.2.
- › All 3G-V Industrial Lever Block gears are fitted with industrial roller bearings.
- › Incorporating a safety overload clutch (limiter) mechanism, an added safety precaution, as the handle cuts out at around 30% more than the rated WLL to prevent severe overloading of the lever block.
- › The Overload Clutch therefore reduces downtime, repair costs and extends the service life of the lever block.
- › Each 3G-V Industrial Lever Block is operationally tested to its rated capacity and is supplied with a test certificate relating to its stamped identification side plate.
- › Precision engineered lower hooks with thrust roller bearings for trouble-free operation.



Chain & Lever Blocks



3G-V Industrial Lever Block – With Safety Overload Clutch (Limiter)

Complies to AS1418.2.

Product Code		505075VM	505150VM	505300VM	505600VM	505900VM
Rated Capacity (kg)		0.75	1.5	3	6	9
Colour		Orange	Orange	Orange	Orange	Orange
Test Load	(t)	1.125	2.25	4.5	9.0	13.5
Standard lift	(m)	1.5	1.5	1.5	1.5	1.5
Min. distance between two hooks	(mm)	295	335	450	542	645
Efforts required at capacity	(N)	140	234	363	370	420
No. of load chains	-	1	1	1	2	3
Diameter of load chain	(mm)	6	7.1	9	9	10
Dimensions	A (mm)	152	152	175	195	195
Dimensions	B (mm)	128	128	148	181	366
Dimensions	C (mm)	295	295	335	450	720
Dimensions	D (mm)	256	256	368	368	368
Dimensions	E (mm)	26	26	38	37	64
Weight	(kg)	7.7	10.6	20.0	28.0	43

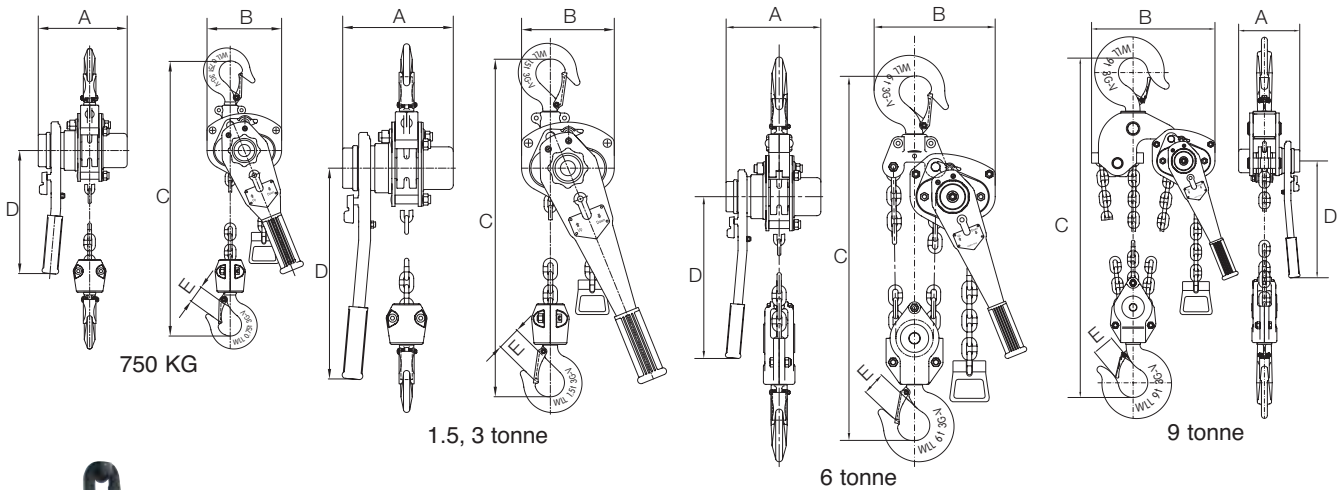

Precision engineered lower hooks with thrust roller bearings for trouble-free operation.



Chain & Lever Blocks



LIFTALL 3G-V Industrial Chain Blocks With Safety Overload Clutch

Model: 3G-V Capacities: 500kg to 20 tonne

The 3G-V Industrial Chain Blocks feature safety load limiting clutch protection which results in greater work safety when lifting. This range of chain blocks has been carefully developed to comply with Australian Standards. They are to be used for vertical lifts only. If they are side loaded or used horizontally, jamming of the load chain and damage to the blocks may occur.

Features

- › The 3G-V Industrial Chain Block has all the features of the 3G lever blocks, with added benefits
- › The load chain is Grade 80 Alloy Steel, black finish, heat treated, calibrated and marked according to Australian standard of AS1418.2.
- › All 3G-V Industrial Chain Block gears are fitted with industrial roller bearings.
- › Incorporating a safety overload clutch (limiter) mechanism, an added safety precaution, as the handle cuts out at around 30% more than the rated WLL to prevent severe overloading of the chain block.
- › The Overload Clutch therefore reduces downtime, repair costs and extends the service life of the chain block.
- › Every 3G-V Industrial Chain Block is operationally tested to its rated capacity and supplied with a test certificate, relating to its stamped identification side plate.
- › 'ID' plates and rivets are supplied in stainless steel in order to avoid dangerous sparking, making them ideal for underground mining.
- › A comprehensive range of spare parts are available, and Robertsons can provide full repair facilities and retesting to NATA specifications.



Chain & Lever Blocks



Product Code		502053VM	502103VM	502203VM	502303VM	502503VM	502603VM	502703VM
Rated Capacity	(t)	0.5	1	5	3	5	10	20
Standard Lift	(m)	3	3	3	3	3	3	3
Falls of Chain		1	1	1	2	2	4	8
Effort to lift Rated Capacity	(N)	231	309	320	360	414	420	870
Test Load	(kN)	6.3	12.5	25	37.5	75	125	250
Net Weight	(kg)	7.75	11.9	18.5	24	42.4	78	162
Load Chain Diameter	(mm)	5	6	8	7.1	10	10	10
Weight per extra metre lift	(kg)	1.5	1.8	2.3	4.2	4.9	9.8	19.6
Clearance Dimensions								
A	(mm)	115	143	152	148	181	181	209
B	(mm)	136	156	198	182	266	365	625
C	(mm)	270	317	414	465	636	798	890
D	(mm)	25	27	36	38	48	57	81

Note: In addition to standard 3 and 6 metre lifts other chain lengths are available on request.

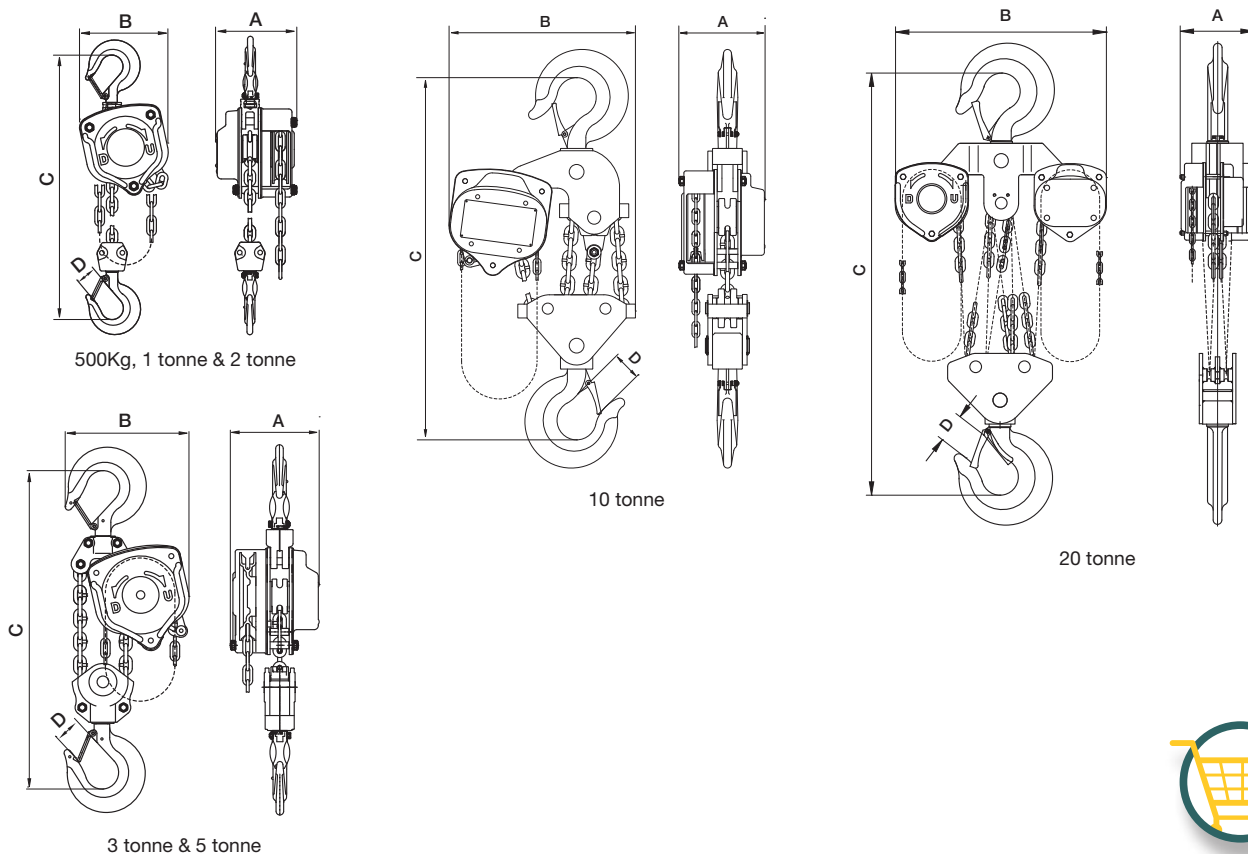

Chain & Lever Blocks

Vital Chain Blocks

Model: Vital Series Capacities: 500kg to 20 tonne

Vital chain blocks are suited for many applications in the mining, construction, industrial and automotive industry. The capacities vary from 0.5 tonne to 20 tonne and all chain blocks can be supplied with overload protection for added security of use.

Features

- > Manufactured in Japan using optimum high quality steel which conforms to the strict JIS & ISO regulations.
- > All Vital models are manufactured to comply with AS1418.2.
- > Designed for long-term use while providing the lowest possible per-use cost.
- > Can be supplied close coupled and extra close coupled to girder trolleys to alleviate headroom restrictions.
- > **Note: All Vital chain blocks can be supplied with 'overload protection'.**
- > Customised lift heights are available upon request.
- > Quality caged needle bearings on load sheave and thrust bearings on bottom hook.
- > Hardened alloy steel load chain with embossed identification, marked as per relevant standards.
- > Load Chain exceeds Australian Standards with a 5:1 Safety Factor.

Dimensions in mm

Product Code	VCB050	VCB100	VCB150	VCB200	VCB300	VCB500	VCB750	VCB910	VCB915	VCB920
Model	05VH5	10VH5	15VH5	20VH5	30VH5	50VH5	75VH5	90VH5	92VH5	93VH5
Rated Capacity (t)	0.5	1.0	1.5	2.0	3.0	5.0	7.5	10.0	15.0	20.0
Standard Lift Height (m)	3.0	3.0	3.0	3.0	3.0	3.0	3.0	3.0	3.0	3.0
Pull to lift load (kg)	25	33	34	34	35	39	41	41	41x2	41x2
Net Weight (kg)	8.6	11.5	13.8	21.6	23.0	41.0	60.5	78.0	150.0	190.0
A (mm)	127	147	147	179	147	179	179	179	207	207
B (mm)	144	157	174	204	206	263	345	367	745	873
C (mm)	305	345	370	425	505	635	740	760	850	870
D (mm)	27	30	34	37	43	47	67	67	87	87

Note: Vital chain blocks with customised lift heights are available



Chain & Lever Blocks

Vital Lever Blocks

Model: Vital Series NR-2 Capacities: 250kg to 9 tonne

The NR-series lever blocks feature the “free-wheeling” braking system which enables fast and easy operation. There is a minimum load requirement of 10% of the Working Load Limit to ensure that the braking system remains operative and continues to support the load. These lever blocks are ideally suited for the shipbuilding, construction, mining and power transmission industries.

Features

- › Manufactured in Japan using optimum high quality steel which conforms to the strict JIS & ISO regulations.
- › All Vital models are manufactured to comply with AS1418.2.
- › One-touch operation for free chain adjustment.
- › Vital lever blocks can be supplied with overload protection for added security of use (excluding 250kg and 500kg models).

- › The unique design of the bottom hook prevents slipping and ensures safe operation.
- › Hardened alloy steel load chain with embossed identification, marked to the relevant standards.
- › Load Chain Exceeds Australian Standards with 5:1 Safety Factor.
- › Minimum load requirement of up to 10% of the Working Load Limit to ensure the operation of the braking system. E.g. a 1.5 tonne lever block requires a minimum load of 150kg.
- › Light loading; not suitable for tandem operations. If one of the lever blocks used in the tandem experiences an increase in the shared load and the other is reduced below the minimum load, inoperative breaks may occur and this could cause for the load to fall.



Product Code	VLB202	VLB205	VLB207	VLB210	VLB215	VLB230	VLB260	VLB290
Model	NR2-03	NR2-05	NR2-08	NR2-10	NR2-15	NR2-30	NR2-60	NR2-90
Rated Capacity (t)	0.25	0.5	0.8	1.0	1.6	3.2	6.3	9.0
Standard Lift Height (m)	1.0	1.5	1.5	1.5	1.5	1.5	1.5	1.5
Pull to lift load (kg)	30	34	21	23	27	38	39	40
Net Weight (kg)	1.9	3.5	6.0	7.2	9.8	16.6	27.0	47.3
Chain Size (mm)	4.0	5.0	5.6	6.3	7.1	9.0	9.0	9.0
No. of Falls	1	1	1	1	1	1	2	3

Note: Vital lever blocks with customised lift heights are available.

Chain & Lever Blocks

Model: Vital – VR-2 Series Capacities: 800kg to 6.3 tonne

The VR-series lever blocks feature a “lock-in and lock-out” braking system which is the more traditional style with a free-wheeling system requiring the disengagement of the gear drive mechanism which is impossible with any load suspended on it. These lever blocks are ideally suited for the (underground) mining, aerospace and energy industries.

Features

- › Manufactured in Japan using optimum high quality steel which conforms to the strict JIS & ISO regulations.
- › Manufactured to comply with AS1418.2.
- › Vital lever blocks can be supplied with overload protection for added security of use (excluding 250kg and 500kg models).
- › The unique design of the bottom hook prevents slipping and ensures safe operation.
- › Easy two-step operation to prevent accidental free-wheeling.
- › Hardened alloy steel load chain with embossed identification, marked as to the relevant standards.
- › Load Chain Exceeds Australian Standards with 5:1 Safety Factor.
- › Suitable for tandem lifting applications.

Product Code	VLB107	VLB115	VLB130	VLB160
Model	VR2-08	VR2-15	VR2-30	VR2-60
Rated Capacity (t)	0.8	1.6	3.2	6.3
Standard Lift Height (m)	1.5	1.5	1.5	1.5
Pull to lift load (kg)	15	18	38	39
Net Weight (kg)	6.9	9.7	16.3	26.7
Chain Size (mm)	6.3	7.1	9.0	9.0
No. of Falls	1	1	1	2

Note: Vital lever blocks with customised lift heights are available.

Model	VR2-08	VR2-15	VR2-30	VR2-60
A (mm)	148	163	191	191
B (mm)	128	148	181	244
C (mm)	295	355	405	550
D (mm)	260	370	370	370
E (mm)	27	34	43	47

Note: Vital lever blocks with customised lift heights are available.

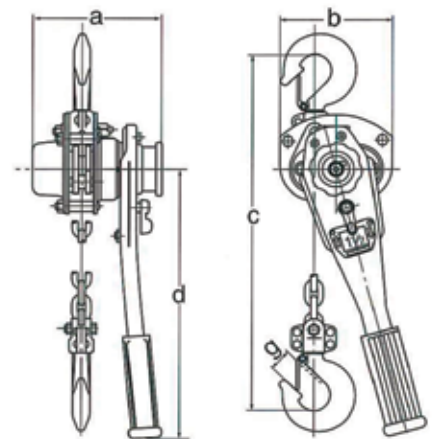

Chain & Lever Blocks



PWB Anchor M3 Chain Blocks

Model: M3 Capacities: 500kg to 10 tonne

The PWB Anchor M3 Series Chain Blocks have been designed for maximum durability and safety for continuous heavy-duty industrial applications. Available in standard lift heights of 3 and 6 metres, these superior units can be close coupled to PWB Anchor Push and Geared Trolleys for further reduced headroom. Optional lift heights also available.

Product Code (3m lift)	Product Code (6m lift)	Capacity	Headroom (mm)	Close Headroom (mm)	Chain Dia. (mm)	Chain Falls	Net Weight (kg)
43269	47769	500kg	360	405	5.0	1	10.0
43271	47444	1 tonne	410	440	6.3	1	11.5
43273	46637	1.5 tonne	470	495	7.1	1	14.5
43275	47882	2 tonne	500	520	8.0	1	21.0
43277	47883	3 tonne	540	595	7.1	2	24.0
43279	47884	5 tonne	640	720	9.0	2	41.0
43281	63286	7.5 tonne	810	865	9.0	3	63.0
49575	49577	10 tonne	780	890	9.0	4	83.0

Note: Also available with Overload Protection.



PWB Anchor L5 Series Lever Hoists

Model: L5 Series Capacities: 800kg to 9 tonne

The PWB Anchor L5 Series Lever Hoist from KITO Japan are lightweight, compact and designed for heavy-duty work in the most rigorous and demanding applications. All models feature the patented 'free-wheel safety brake mechanism' and nickel plated load chain. Supplied in standard lift heights of 1.5 metres and selected 3 metre models, with optional lift heights also available.

Product Code (1.5m lift)	Capacity (t)	Product Code (3m lift)	Headroom (mm)	Lever Length (mm)	Load Chain Dia (mm) x Fall	Weight (kg)
44202	0.8	45890	280	245	5.6x1	5.7
44203	1.0	62575	300	245	5.6x1	5.9
44204	1.6	45891	335	265	7.1x1	8.0
44205	2.5	61917	375	265	8.8x1	11.2
44206	3.2	45892	395	415	10.0x1	15.0
44207	6.3	45893	540	415	10.0x2	26.0
44208	9.0	61498	680	415	10.0x3	40.0

Note: Also available with Overload Protection.



Trolleys & Clamps



Trolleys & Clamps

Push and Geared Girder Trolleys

Features

- › Our Push and Geared Girder Trolleys are colour coded for safer lifting capacity recognition.
- › **Colour coded to International Lifting Standards**
- › Designed to run on either R.S.J. or Universal Beams.
- › Fully adjustable to suit varying flange widths up to a maximum of 350mm with the simple addition or subtraction of spacers or nuts on a suspension pin.
- › Easy and simple mounting in different locations.
- › Independent hanging eye for easy attachment of chain blocks.
- › Precision ball bearing trolley wheels complete with dust cover and circlip.
- › Lightweight robust all-steel construction.
- › Anti-derailment end plates fitted as standard for added safety.
- › Anti-tilt blocks fitted as standard for additional safety.
- › Hand chain on geared trolleys has a special, corrosion resistant Zinc dichromate (gold) finish.
- › Each Girder Trolley has an individual serial number stamped on the stainless steel identification plate. This number coincides directly to the test certificate of the product, for quick and easy tracing and reference.
- › Every Girder Trolley is operationally tested to 150% of its rated capacity and comes with a test certificate.
- › Spare trolley wheels are available, complete with full repair facilities and re-testing to NATA specifications.



**Colour
Coded for
Safety**

Trolleys & Clamps



Push Girder Trolleys

Complies to AS1418.2.

Orange in colour

Product Code	522005S	522010S	522015S	522020S	522030S	522050S	522100S	522200S
Capacity WLL (t)	0.5	1.0	1.5	2.0	3.0	5.0	10.0	20.0
Beam Width (mm)	50-152	64 - 203	74 - 203	88 - 203	100 - 305	114 - 305	124 - 305	136 - 305

Note: Contact your local Robertsons branch for full dimensions.

Push and Geared Girder Trolleys are not designed for passenger elevator applications and must not be used for this purpose. Selection and calculation of the proper beam construction is the responsibility of the user.

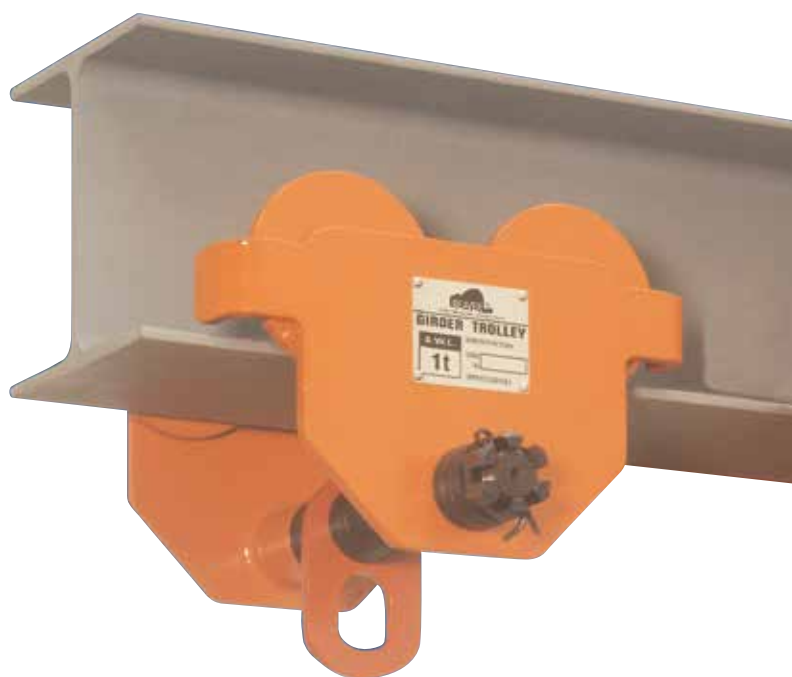

Trolleys & Clamps

Geared Girder Trolleys



Complies to AS1418.2.

Colour Coded to Match International Lifting Standards.

Product Code	523010S	523020S	523030S	523050S	523100S	523200S	523300S
Rated Capacity (t)	1	2	3	5	10	20	30
Colour Code	Violet	Green	Yellow	Red	Orange	Orange	Orange
Proof Load (kN)	14.71	29.42	44.13	61.29	122.58	245.17	367.74
Adjustable Beam Width (mm)	64-203	88-203	100-305	114-305	124-305	136-305	175-305
Standard Lift (m)	3	3	3	3	3	3	3
Effort at Rated Capacity (N)	50	90	95	140	240	250	250
Minimum Radius of Curve (m)	1.0	1.1	1.3	1.4	2.0	3.5	6.0
A (overall width) (mm)	338	349	464	476	510	600	673
B (length) (mm)	246	276	332	377	424	555	710
C (mm)	222	263	309	353	396	498	598
D (mm)	40	52	58	64	64	75	90
E (mm)	38	38	40	42	45	58	65
F (mm)	1.5-3	1.5-3	1.5-3	2-3.5	2-3.5	2-3.5	2-3.5
G (mm)	30	36	42	48	48	55	65
H (headroom) (mm)	125	150	171	186	190	233	285
I (flange dia.) (mm)	95	108	131	144	176	226	286
J (mm)	68	80	100	110	136	175	200
L1 (mm)	120	132	155	168	200	272	330
L2 (mm)	23	26	29	35	52	78	100
L3 (mm)	8	8	10	10	25	58	82
Net Weight (kg)	14.5	21.5	31	46	75	172	337

Push and Geared Girder Trolleys are not designed for passenger elevator applications and must not be used for this purpose. Selection and calculation of the proper beam construction is the responsibility of the user.

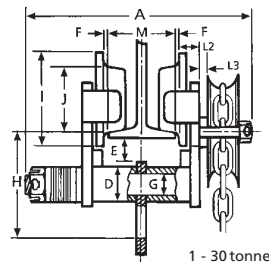
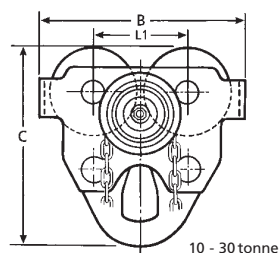
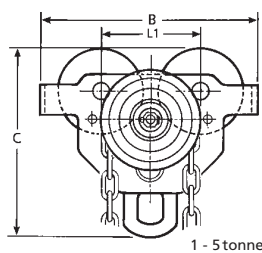

Trolleys & Clamps

Close Headroom Push Girder Trolleys



(to suit 3G chain blocks) Complies to AS1418.2.

Product Code	522005SC	522010SC	522020SC	522030SC	522050SC
Rated Capacity (t)	0.5	1	2	3	5
Colour Code	White	Violet	Green	Yellow	Red
Proof Load (kN)	7.35	14.71	29.42	44.13	61.29
Adjustable Beam Width (mm)	50-152	64-203	88-203	100-305	114-305
Minimum Radius of Curve (m)	0.8	0.9	1	1.2	1.3
A (overall width) (mm)	236	303	317	435	457
B (length) (mm)	199	246	276	332	377
C (mm)	31.5	164	183	224	246
H (mm)	300	385	480	520	640
S (mm)	30	38	38	40	42
F (mm)	1.5-3	1.5-3	1.5-3	1.5-3	1.5-3
M (mm)	50-152	64-203	88-203	100-305	114-305
Net Weight (kg)	14	23.5	39	59.5	89

Push and Geared Close Coupled Girder Trolleys are not designed for passenger elevator applications and must not be used for this purpose. Selection and calculation of the proper beam construction is the responsibility of the user.

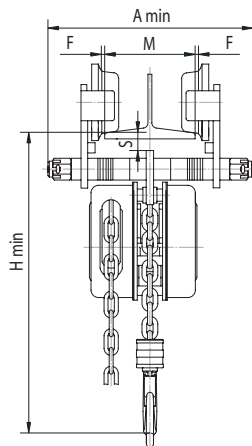
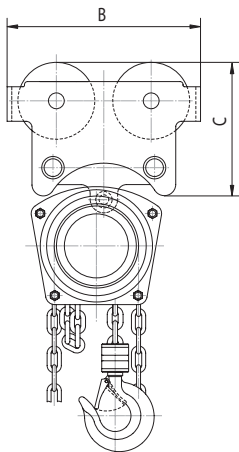

Trolleys & Clamps

Close Headroom Geared Girder Trolleys



(to suit 3G chain blocks) Complies to AS1418.2.

Product Code	523010SC	523020SC	523030SC	523050SC
Rated Capacity (t)	1	2	3	5
Colour Code	Violet	Green	Yellow	Red
Proof Load (kN)	14.71	29.42	44.13	61.29
Running Height (m)	2.5	2.5	2.5	2.5
Chain Pull (full load) (kg)	50	90	95	140
Adjustable Beam Width (mm)	64-203	88-203	100-305	114-305
Minimum Radius of Curve (m)	0.9	1	1.2	1.3
A (overall width) (mm)	334	343	459	475
B (length) (mm)	246	276	332	377
C (mm)	164	183	224	246
H (mm)	385	480	520	640
S (mm)	38	38	40	42
F (mm)	1.5-3	1.5-3	1.5-3	1.5-3
M (mm)	64-203	88-203	100-305	114-305
Net Weight (kg)	27.5	43	63.5	93

Push and Geared Close Coupled Girder Trolleys are not designed for passenger elevator applications and must not be used for this purpose. Selection and calculation of the proper beam construction is the responsibility of the user.

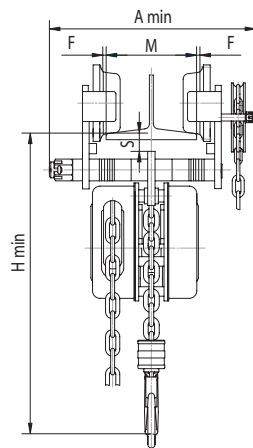
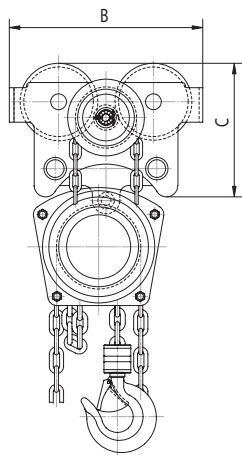

Trolleys & Clamps



Pipe Trolley

Product Code	Capacity WLL (kg)	Pipe Dia. (mm)	A (mm)	B (mm)	C (mm)	D (mm)	E (mm)	F (mm)	G (mm)	Weight (kg)	UOM
522003PT	300	60	147.5	160	22	68	160	60	17	2.5	Each

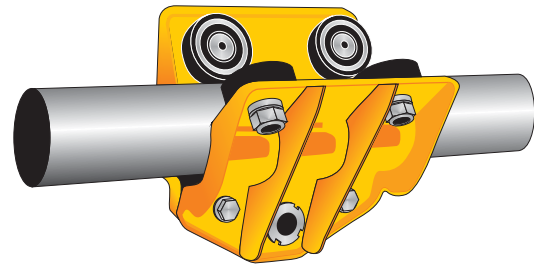
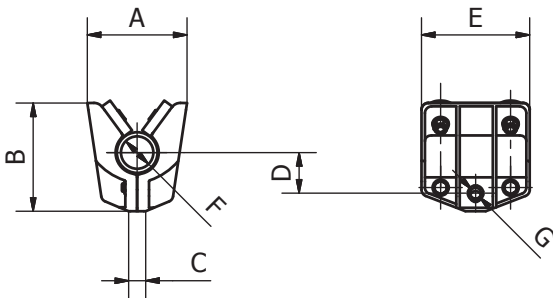

Single Flange Steel Plain Trolley Wheels

Product Code	Capacity WLL (kg)	L (mm)	H (mm)	i (mm)	S (mm)	d1 (mm)	D (mm)	P (mm)	G (mm)	W (mm)	Weight (kg)	UOM
525005S	0.5	52.5	27	23	6	24	55	79	24	16	17.6	Each
525010S	1	60	30	27	8	27	68	95	27	19	20.6	Each
525020S	2	72	34	34	10	35	80	108	35	25	27	Each
525030S	3	83	39	41	12	42	100	131	42	35	32	Each
525050S	5	102	50	49	16	45	110	144	45	35	38.5	Each
525100S	10	129.5	58	68	30	60	136	176	60	48	52	Each

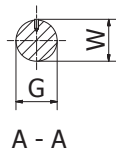
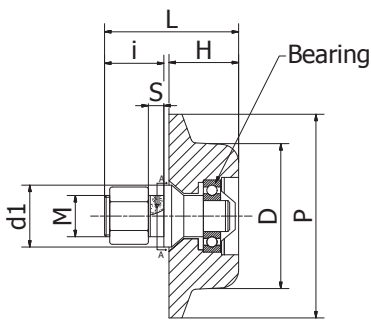

Trolleys & Clamps



Girder Clamps

A range of colour coded Girder Clamps, that offers instant recognition of the clamp capacity to the user. Designed to provide a quick and versatile point for all your lifting, rigging and hoisting needs.

Features

- › Girder Clamps are colour coded for safer lifting capacity recognition.
- › The threaded adjustment mechanism easily attaches to the beam or girder flange to provide a safe and secure grip.
- › Additional security is provided by threaded adjustment screws secured by using the countersunk allen head screw to lock the threaded adjustment bar in position with a copper flat.
- › Easy and simple mounting for permanent or temporary use in different locations.
- › Adjustable to fit a wide range of flange widths and beams.
- › Special clamp jaw design applies load away from the edge of the flange, reducing flange stress.
- › Built-in load bar provides reduced headroom.
- › Robust, all steel construction.
- › Every Girder Clamp has an individual serial number stamped on the body of the clamp and also on the stainless steel identification plate. This number coincides directly to the test certificate of the product for quick and easy tracing and reference.
- › All Girder Clamps are operationally tested to 150% of the Working Load Limit (W.L.L.) and come with individual test certificates.
- › Complies to AS4991.



Trolleys & Clamps

Girder Clamps – Model Type: YC – Industrial



Complies to AS1418.2 & AS4991.

Colour Coded to Match International Lifting Standards.

Product Code		270010Y	270020Y	270020YA	270030Y	270050Y	270100Y
Working Load Limit (kg)		1000	2000	2000	3000	5000	10000
Colour Code		Violet	Green	Green	Yellow	Red	Orange
Adjustable Beam Width (mm)		75-230	75-230	75-360	80-320	90-320	90-320
Net Weight (kg)		3.8	4.6	6.5	9.2	11.0	17.2
A max. (mm)		246	246	380	320	320	320
B	min. (mm)	186	186	205	232	242	268
	max.(mm)	350	350	485	455	455	480
C	(mm)	66	74	76	102	110	118
D	(mm)	4	6	6	8	10	12
E	(mm)	215	215	271	255	255	275
F	min (mm)	90	90	150	143	145	133
	max (mm)	133	133	232	195	195	185
G min.	(mm)	44	44	57	75	75	66
H	(mm)	20	20	22	22	28	38
K	min. (mm)	14	14	14	30	30	34
	max. (mm)	21	21	21	34	34	35

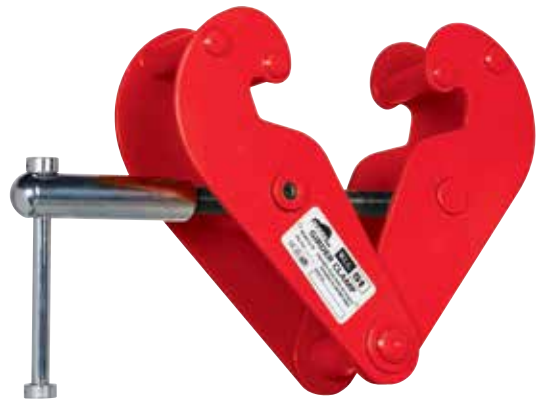
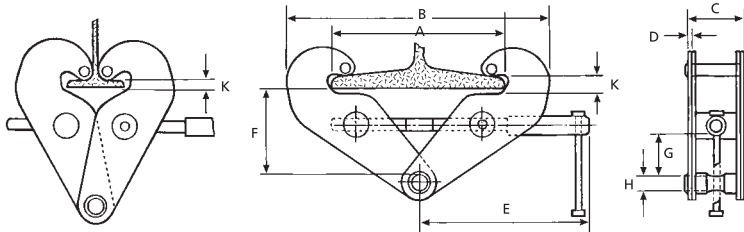

Trolleys & Clamps

Entertainment Girders Clamps

Model Type: YE. Complies to AS1418-2 & AS4991.

Black Powder Coated.

Product Code	270010YE	270020YE
WLL (kg)	1000	2000
Colour	Black	Black
Beam Width (mm)	75-250	75-250
Net Weight (kg)	3.80	4.80
A Max. (mm)	266	266
B Min. (mm)	186	186
B Max. (mm)	400	400
C (mm)	66	74
D (mm)	4	6
E (mm)	230	230
F Min. (mm)	90	90
F Max. (mm)	115	115
G Min. (mm)	44	44
H (mm)	20	20
K Min. (mm)	14	14
K Max.(mm)	21	21

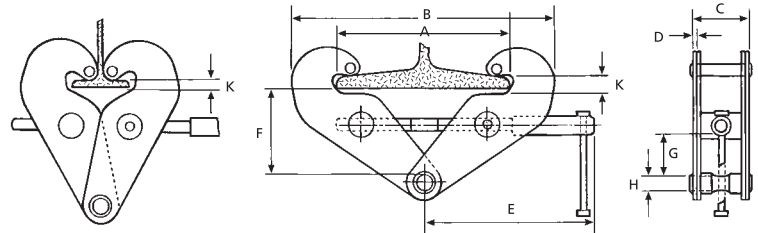



Integral Push Trolley and Girder Clamp

The Integral Push Trolley and Girder Clamp is designed to provide a quick and easy attachment to overhead beams for transporting loads for permanent or temporary mounting in different locations. The integral clamp is adjustable to the beam width in the same manner as the Girder Clamp (model YC), by rotating the threaded spindle. Complies to AS1418.2

Features

- › For additional safety the threaded adjustment mechanism is secured by tightening the locking lever against the sideplate.

- › Threaded spindle mechanism, zinc plated for superior corrosion protection.
- › Easily adjustable to suit a wide range of flange widths and beams from 75mm to 200mm.
- › Robust steel construction with durable enamel paint finish in yellow for YT and black for YTE models.
- › Built-in load bar for reduced headroom.

- › Every Integral Push Trolley and Girder Clamp has an individual serial number stamped on the body of the clamp and also onto the aluminium identification plate which is securely mounted to the trolley side plate. This number coincides directly to the test certificate of the product for quick and easy tracing and reference.
- › All Integral Push Trolley and Girder Clamps are operationally tested to 150% of the rated capacity and come with individual test certificates.

YT Complies to AS1418.2.

Yellow Powder Coated Model Type.

Product Code	270010YT	270020YT	270030YT
WLL (kg)	1000	2000	3000
Beam width (mm)	75-200	75-200	75-200
A (mm)	80-152	106-155	128-171
D (mm)	42	42	50
E (mm)	20	20	22
I (mm)	71.5	71.5	95.5
L (mm)	260	260	310
L1 (mm)	130	130	150
M (mm)	M16	M18	M24
O (mm)	60	60	60
P (mm)	195	205	220
T (mm)	155	139	155
t (mm)	25	25	25
Net Weight (kg)	9.40	9.90	17.50

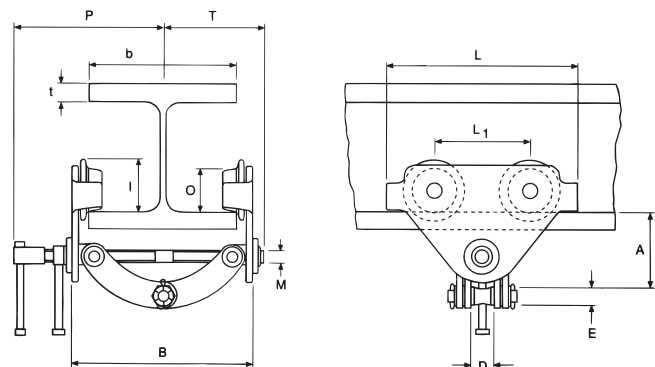

Hoists

LIFTALL Electric Chain Hoists and Trolleys

Capacities: 500kg to 3 tonne

Cost efficient and robust, the LIFTALL Electric Chain Hoists and Trolleys are the first choice when you need to lift heavy loads to a budget. The all steel construction ensures durability and strength, and having Plated European Load Chain you know the most important component won't let you down. Beaver have invested time and money on research and development to guarantee the Beaver LIFTALL Electric Chain Hoists and Trolleys will give you the trouble free service you demand.

Features

- › Models available in single phase 240volts X 50Hz and 3 phase 415 volts X 50 Hz.
- › Capacities from 500 kg to 3000 kg in both single and 3 phase.
- › Overload clutch to prevent damage from overloading.
- › Powder coated finish.
- › Grade T(80) zinc plated, calibrated European Load Chain for increased resistance against corrosion and wear.
- › Standard lifts of 3 and 6 metres. Custom lifts are available on request.
- › Chain inspection gauge supplied with every hoist (in order to self evaluate wear and tear on load chain).
- › 5 pocket precision machined load sprocket for smooth action.
- › Reduction gear box is totally sealed, grease filled design ensuring that all components remain lubricated.
- › Zinc plated travel limiting springs.
- › European Electric Controls (contactors and switch gear).
- › IP54 protection on electric hoist for dust and water proof protection.
- › Thermal protection on hoist motor.
- › Heavy duty **asbestos free** DC Brake (for fast actuation).
- › Upper and lower limit switches fitted as standard to prevent over-travel.
- › Contactor isolation **Emergency Stop**
- › 24 Volt control via IP65 European Pendant for increased safety.
- › Pendant control suspended by external wire rope (Strainer Wire).
- › Sealed swivel bearing in bottom hook for 360° operation.
- › Heavy duty cast safety latches fitted to top and bottom hook on all models.
- › High duty cycle (up to 40% ED on 3 phase models).
- › Chain containers on all hoists.
- › Comprehensive instruction manual, including wiring diagrams and parts breakdown, supplied with every hoist.
- › Test certificate supplied with every hoist confirming that it is tested to AS1418.2- 1997.
- › Radio controls and special options available on request.

LIFTALL



Hoists



LIFTALL Electric Hoists

Model Type: BEL-1. 240 volt 50Hz (Single Phase Models) Complies to AS1418.2

Product Code	Rated Capacity (kg)	Lift Height (m)	Lifting Speed m/min 50Hz	Hoist Motor Single Phase			Load Chain		Test Load (t)	Min. Headroom G (mm) Max.	Min. Weight (kg) Approx.
				Output (kw) 50Hz	Ins Class	% ED	Dia. (mm)	No. of falls			
BEL1053S	500	3	5	0.6	E	40	7.0	1	0.625	545	64
BEL1056S	500	6	5	0.6	E	40	7.0	1	0.625	545	68
BEL1103S	1000	3	5	1.2	E	40	7.0	1	1.25	595	65
BEL1106S	1000	6	5	1.2	E	40	7.0	1	1.25	595	69
BEL1203SD	2000	3	2.5	12	E	40	7.0	2	2.5	700	72
BEL1206SD	2000	6	2.5	12	E	40	7.0	2	2.5	700	79
BEL1303ST	3000	3	1.3	1.2	E	40	7.0	3	3.75	790	80
BEL1306ST	3000	6	1.3	1.2	E	40	7.0	3	3.75	790	90

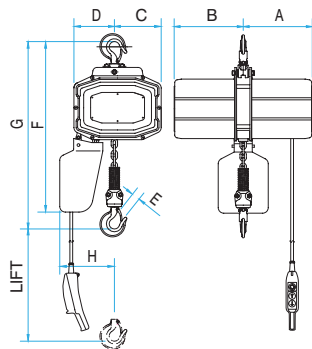

500kg & 1,000kg - Single Fall

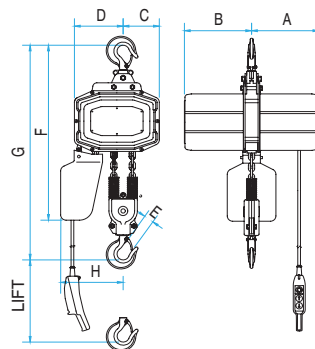

2,000kg - Double Fall

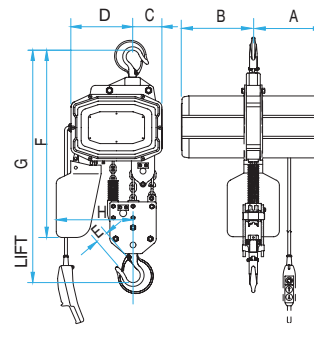

3,000kg - Triple Fall

Dimensions in mm

Product Code	Rated Capacity (kg)	Major Dimensions Approx.						
		A (mm)	B (mm)	C (mm)	D (mm)	E (mm)	F (mm)	H (mm)
BEL1053S	500	249	249	168	146	25	565	195
BEL1056S	500	249	249	168	146	25	565	195
BEL1103S	1000	249	249	168	146	30	614	195
BEL1106S	1000	249	249	168	146	30	614	195
BEL1203SD	2000	249	249	180	134	33	665	235
BEL1206SD	2000	249	249	180	134	33	665	235
BEL1303ST	3000	249	249	180	134	41	760	360
BEL1306ST	3000	249	249	180	134	41	760	360

Longer lift heights are available on request. Pendant length is 1 metre less than lift height (as Standard).

All hoists supplied with top suspension hook. IP 54 rating on all hoists.

Hoists

LIFTALL Electric Hoists



Model Type: BEL. 415volt 50Hz (Three Phase Models) Complies to AS1418.2

Product Code	Rated Capacity (kg)	Lift Height (m)	Lifting Speed m/min 50Hz	Hoist Motor Single Phase			Load Chain		Test Load (t)	Min. Headroom G (mm) Max.	Min. Weight (kg) Approx.
				Output (kw) 50Hz	Ins Class	% ED	Dia. (mm)	No. of falls			
BEL2053S	500	3	6.3	0.8	F	40	1	0.625	545	64	64
BEL2056S	500	6	6.3	0.8	F	40	1	0.625	545	68	68
BEL2103S	1000	3	6.3	1.6	F	40	1	1.25	595	65	65
BEL2106S	1000	6	6.3	1.6	F	40	1	1.25	595	69	69
BEL2203SD	2000	3	3.2	1.6	F	40	2	2.5	700	72	72
BEL2206SD	2000	6	3.2	1.6	F	40	2	2.5	700	79	79
BEL2303ST	3000	3	2.1	1.6	F	40	3	3.75	790	80	80
BEL2306ST	3000	6	2.1	1.6	F	40	3	3.75	790	90	90

Dimensions in mm

Product Code	Rated Capacity (kg)	Major Dimensions Approx.							
		A (mm)	B (mm)	C (mm)	D (mm)	E (mm)	F (mm)	H (mm)	
BEL2053S	500	249	249	168	146	25	565	195	
BEL2056S	500	249	249	168	146	25	565	195	
BEL2103S	1000	249	249	168	146	30	614	195	
BEL2106S	1000	249	249	168	146	30	614	195	
BEL2203SD	2000	249	249	180	134	33	665	235	
BEL2206SD	2000	249	249	180	134	33	665	235	
BEL2303ST	3000	249	249	180	134	41	760	360	
BEL2306ST	3000	249	249	180	134	41	760	360	

Longer lift heights are available on request. Pendant length is 1 metre less than lift height (as Standard).

All hoists supplied with top suspension hook. IP 54 rating on all hoists.

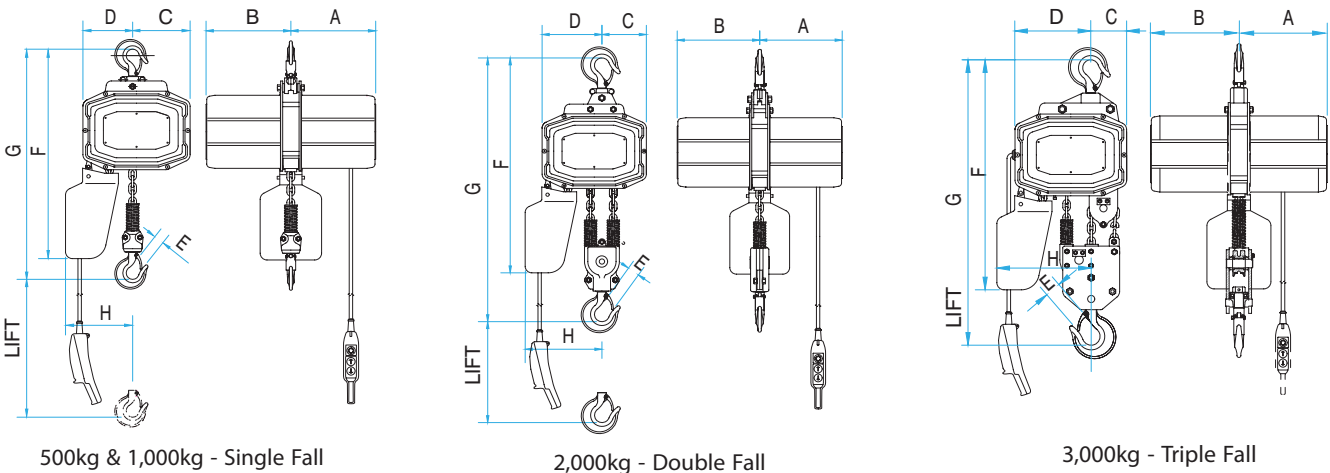

LIFTALL Electric Trolleys



Model Type: BET. 415 volt 50Hz (Three Phase Model)

Product Code	Rated Capacity (kg)	Beam Width (mm)	A (mm)	B (mm)	C (mm)	D (mm)	E (mm)	Running Speed m/min	INS Class	% ED	Net Weight (kg)
BET1000	1000	75 - 180	27.5	265	260	27	10	20	B	20	34
BET2000	2000	75 - 180	36.5	265	260	36	10	20	B	20	35
BET3000	3000	75 - 180	42.5	265	260	42	12	15	B	20	37

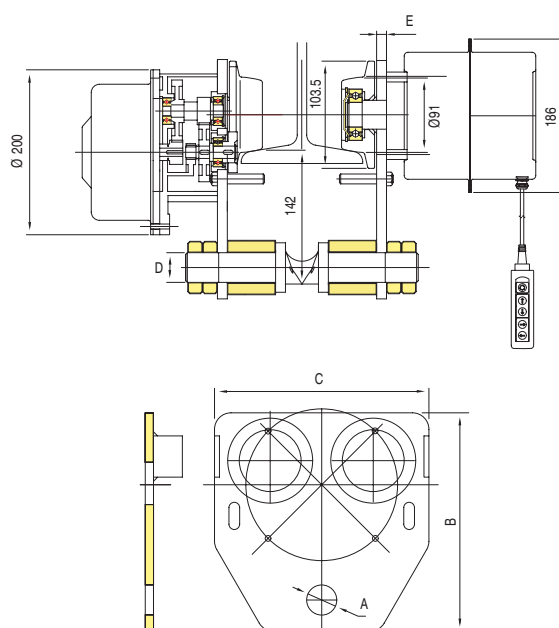

Hoists

PACIFIC Electric Chain Hoists

The Pacific Electric Chain Hoists offer a great balance between quality and price. The models vary from 250kg to 2 tonne capacity and are all tested to Australian Standards. All hoists are inclusive of many features which makes them suited for most applications. Optional motorised trolleys are available to complete the package.

Features

- › IP65 pendant with 24 volt control for operator safety.
- › Overload protection clutch prevents damage caused by overloading.
- › Inclusive of DC Brake which automatically engages in the event of a power failure.
- › Completely enclosed design to withstand harsh conditions.
- › Upper and lower electrical limit switches.
- › Grade 80 zinc plated load chain supplied as standard.
- › Motor thermal protection on all Pacific Electric Chain Hoists.
- › Fuse protection provided for both primary and secondary control circuits.
- › IP54 protection rating on all electric hoists and trolleys.
- › Reverse phase protection relay on all models excluding 250kg.
- › Optional radio remote control.



Pacific Electric Chain Hoists – 415Volt, 50 Hz

Product Code/Model	PEH025	PEH050	PEH100	PEH200
Rated Capacity (kg)	250	500	1000	2000
Standard Lift Height (m)	3	3	3	3
Chain Dimension (mm)	4x12	6.3x19.1	7.1x20.2	7.1x20.2
Speed (m/min)	12/3	10/2.5	8/2	4/1
Motor (kW)	0.6/0.15	1.1/0.28	1.5/0.37	1.5/0.37
E.D. Rating (%)	40/20	40/20	40/20	40/20
Load Chain Fall No.	1	1	1	2
Weight (kg)	30	42	57	62

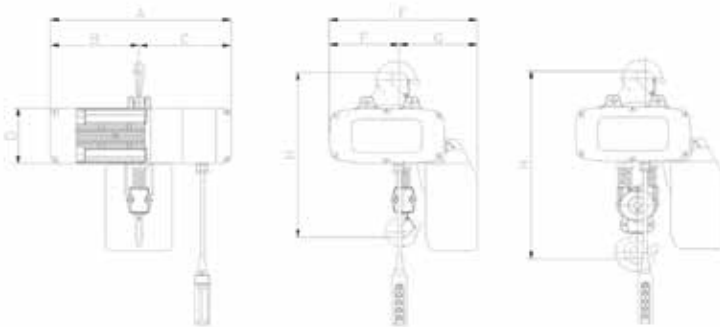

Dimensions in mm

Product Code/Model	PEH025	PEH050	PEH100	PEH200
A (mm)	380	468	487	487
B (mm)	175	221	240	240
C (mm)	205	247	248	248
D (mm)	135	156	170	170
E (mm)	299	366	398	398
F (mm)	143	186	188	188
G (mm)	156	180	210	210
H (mm)	376	485	520	592

Hoists

Motorised Trolleys – 415 Volt, 50Hz



Product Code/Model	PET050	PET100	PET200	PET055	PET105	PET205
Rated Capacity (kg)	500	1000	2000	500	1000	2000
Speed (m/min)	10	10	10	20/5	20/5	20/5
Motor (kW)	0.12	0.18	0.37	0.12/0.03	0.18/0.04	0.37/0.09

Pacific Electric Chain Hoists plus Trolley

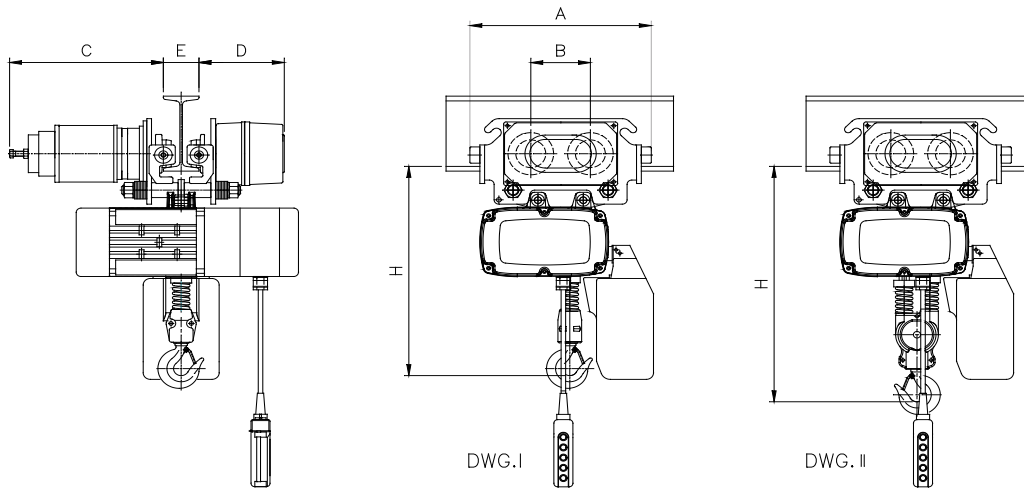

Dimensions in mm

Product Code/Model	PEH025 + PET055	PEH050 + PET050	PEH100 + PET105	PEH200 + PET205
A (mm)	382	382	382	392
B (mm)	125.5	125.5	125.5	159
C (mm)	324	324	324	357
D (mm)	180	180	180	180
E (mm)	75-125	75-125	75-125	100-150
H (mm)	385	483	510	582



Hoists

HITACHI Electric Chain Hoists

Capacities: 250kg to 15 tonne

Hitachi Electric Chain Hoists are suited to most applications. The Hitachi models vary from 250kg to 15 tonne capacity and are available in three or single phase, two speed or single speed, to the Australian Standards – AS1418.2.

Features

- › Operation: fully contactorised with high rated contactors and pendant controls; both fitted with mechanical interlocks and 24 Volt control.
- › Optional IP65 pendant including E-Stop available.
- › Safety Limits: full current and shunt limit switches operate in both directions of hook travel.
- › Overload Limiter
- › All models are fitted with an electro-magnetic, self-adjusting disc type brake to the gearbox and the "F" models have an additional auxiliary centrifugal brake fitted to the motor.
- › High quality Grade 80 zinc plated load chain supplied as standard.
- › IP54 protection rating on all electric hoists and trolleys.
- › Motor thermal protection on all Hitachi models.
- › Optional radio remote control.
- › Ambient temperature requirement of -10 to 40 degrees.
- › Class M4 inclusive of 180 starts per hour.
- › Completely enclosed design.
- › Reverse phase protection relay on all models excluding; 250kg, 500kg and all single phase models.
- › Electric trolleys are fitted with Guide Rollers as standard.

Three Phase / Single Speed Hoists – 415Volt, 50Hz

Product Code/Model	¼S	½S	1S	2S	1F	2F	3F	5F
Rated Capacity (kg)	250	500	1000	2000	1000	2000	3000	5000
Speed (m/min)	10	7.2	4.6	2.3	7.1	6.8	4.1	2.8
Motor (kW)	0.45	0.63	0.8	0.8	1.3	2.4	2.4	2.4
Weight (kg)	28	31	37	49	42	80	99	121
Headroom (mm)	450	450	530	645	535	660	820	1020



Hoists

Three Phase / Two Speed Hoists – 415Volt, 50Hz



Product Code/Model	¼SN	½SN	1SN	2SN	2FN	3FN	5FN
Rated Capacity (kg)	250	500	1000	2000	2000	3000	5000
Speed (m/min)	7.2/1.8	7.2/1.8	4.6/1.2	2.3/0.6	6.8/1.7	4.0/1.0	2.8/0.7
Motor (kW)	0.32/0.08	0.63/0.16	0.8/0.2	0.8/0.2	2.4/0.6	2.4/0.6	2.4/0.6
Weight (kg)	33	36	42	54	96	112	146
Headroom (mm)	450	450	530	645	660	820	1020

Single Phase / Single Speed Hoists – 240Volt, 50 Hz

Product Code/Model	¼S1	½S1	1S1	2S1
Rated Capacity (kg)	250	500	1000	2000
Speed (m/min)	5	3.6	2.3	1.1
Motor (kW)	0.25	0.32	0.4	0.4
Weight (kg)	34	34	39	51
Headroom (mm)	450	450	530	645

Three Phase / Electric Trolleys – 415Volt, 50Hz

Product Code/Model	1ET	2ET	3ET	5ET
Rated Capacity (kg)	1000	2000	3000	5000
ET Speed (m/min)	Single Speed		ET 10.5 or 21.0	
ETN Speed (m/min)	Two Speed		ETN 21.0 / 5.3	
Motor (kW)	0.14	0.14	0.3	0.3
Weight (kg)	33	34	39	51
Min. Radius (m)	1.5	1.8	2.0	3.0
Girder Width (mm)*	75-125	100-150	100-150	125-175

Note: Larger girder widths are available upon request.

Hoists

PACIFIC Porta Hoists

Capacities: 80kg to 500kg

The Pacific Porta Hoists are compact, lightweight 240 volt single phase electric chain hoists. They are available in a durable travel case which makes them the ideal portable solution for lifting, lowering and handling loads up to 500kg. All models are tested to the Australian Standards – AS1418.2.

Features

- › Available in 80kg, 125kg, 250kg and 500kg capacities.
- › Duty cycle rated at 30% ED with 180 starts per hour
- › 18 volt DC low voltage control for safe operation.
- › IP65 pendant control, dual speeds with variable speed slow control for raise and lower.
- › Overload protection clutch prevents damage caused by overloading.
- › All models are supplied as standard with 6 metre height of lift, a 5 metre pendant control, chain bucket and 3 metre power supply cable.
- › Upper and lower electrical limit switches.
- › Supplied with durable travel case.



Product Code/Model	PPH080	PPH125	PPH240	PPH500
Rated Capacity (kg)	80	125	250	500
Standard Lift Height (m)	6	6	6	6
Pendant Length (m)	5	5	5	5
Power Supply 50Hz (volt)	240	240	240	240
Chain Dimension (mm)	4.0x12	4.0x12	4.0x12	4.0x12
Motor Power (kW)	0.3	0.3	0.6	0.6
Speed (m/min)	0-4.8 (variable)/18	0-3.2 (variable)/12.5	0-3.2 (variable)/12.5	0-1.6 (variable)/6.3
IP Rating	54	54	54	54
E.D. Rating (%)	30	30	30	30
Load Chain Fall No.	1	1	1	2
Weight (kg)	17.5	17.5	17.5	20.6

*Additional height of lift is available upon request. Please note that this may vary the size and weight of the hoist and therefore may not fit into the travel case.

Hoists

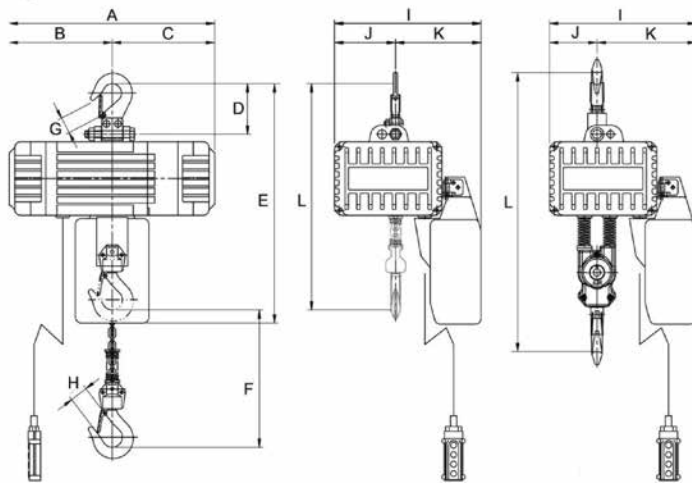

Dimensions in mm

Product Code/Model	PPH080	PPH125	PPH240	PPH500
A (mm)	364	364	364	364
B (mm)	182	182	182	182
C (mm)	182	182	182	182
D (mm)	89	89	89	89
E (mm)	423	423	423	423
F (mm)	3m lift	3m lift	3m lift	3m lift
G (mm)	25	25	25	25
H (mm)	25	25	25	25
I (mm)	260	260	260	260
J (mm)	108	108	108	84
K (mm)	152	152	152	176
L (mm)	400	400	400	494

Hoists

PWB ANCHOR Electric Chain Hoists



Capacities: 250kg to 20 tonne

The PWB Anchor power hoist products have been designed and manufactured for use in a wide variety of industrial applications. PWB Anchor electric and pneumatic hoists range in capacity from 250kg to 20 tonnes and along with their ancillary products, guarantee smooth operation in the manufacturing process.

ER2 Electric Chain Hoist

The PWB Anchor ER2 Electric Chain Hoist is environmentally friendly with its new compact, lightweight and energy efficient design. Coupled with the new MR2 Motorised Trolley, the Er2/MR2 combination allows for easier and accurate load positioning in the workplace.

Features

- › Easy to use.
- › Offers thermal protection to prevent overheating.
- › Upper and lower limit switches.
- › CH (Counter/Hour) meter and variable speed inverter as standard equipment.



ER2 Series Electric Chain Hoist: Single Speed

Product Code 3 (m)	Product Code 6 (m)	Capacity (t)	Model	Lifting Speed (m/min)	Load Chain Dia (mm) x fall	Headroom (mm)
45801	45961	0.25	ER2-003S	9.1	4.3 x 1	350
45802	45962	0.5	ER2-005L	3.8	6.0 x 1	370
45803	45963	0.5	ER2-005S	7.3	6.0 x 1	370
45804	45964	1.0	ER2-010L	3.5	7.7 x 1	430
45805	45965	1.0	ER2-010S	7.1	7.7 x 1	430
45806	-	1.5	ER2-015S	4.5	10.2 x 1	510
45807	45966	2.0	ER2-020L	3.7	10.2 x 1	575
45808	-	2.0	ER2-020S	7.0	10.2 x 1	590
45809	-	2.5	ER2-025S	5.7	11.2 x 1	625
45810	-	3.0	ER2-030S	4.4	10.2 x 2	785
45811	-	5.0	ER2-050S	2.9	11.2 x 2	850

5 metre power supply cable (plug not included) Australian Standard AS1418.2, ASME HST (USA) H4 Duty Class ISO Heavy Duty Classification M4 & M5, FEM (Europe) 1Am & 2m rating

ER2 Series Electric Chain Hoist: Dual Speed with Inverter

Product Code 3 (m)	Capacity (t)	Model	Lifting Speed (m/min)	Load Chain Dia (mm) x fall	Headroom (mm)
45821	0.25	ER2-003IS	10.8-1.8	4.3 x 1	350
45822	0.5	ER2-005IL	4.5-0.8	6.0 x 1	370
45823	0.5	ER2-005IS	8.5-1.4	6.0 x 1	370
45824	1.0	ER2-010IL	4.2-0.7	7.7 x 1	430
45825	1.0	ER2-010IS	8.2-1.4	7.7 x 1	430
45826	1.5	ER2-015IS	5.3-0.9	10.2 x 1	510
45827	2.0	ER2-020IL	4.3-0.7	10.2 x 1	575
45828	2.0	ER2-020IS	8.2-1.4	10.2 x 1	590
45829	2.5	ER2-025IS	6.6-1.1	11.2 x 1	625
45830	3.0	ER2-030IS	5.2-0.9	10.2 x 2	785
45831	5.0	ER2-050IS	3.3-0.6	11.2 x 2	850

5 metre power supply cable (plug not included) Australian Standard AS1418.2, ASME HST (USA) H4 Duty Class ISO Heavy Duty Classification M4 & M5, FEM (Europe) 1Am & 2m rating

MR2 Electric Chain Hoist and Motorised Trolley



The PWB MR2 Electric Chain Hoist and Motorised Trolleys complement the ER Electric Chain Hoist and have been designed for use across a wide variety of industrial applications.

Features

- › Coupled as an ER2/MR2 combination for easier and accurate load position in the work place.
- › Applicable in both single and dual speed models.
- › Highly versatile and easy to use.

Capacity (t)	Model	Headroom* (mm)	Beam Range Standard	Beam Range Optional	Travel (m/min)		Min Radius
					Single Speed	Dual Speed	
0.25	ER2M003	375	58-153	154-305	20 (standard) or 10 (optional)	24/4	0.8
0.5	ER2M005	395	58-153	154-305			0.8
1.0	ER2M010	435	58-153	154-305			0.8
1.5	ER2M015	505	82-178	179-305			0.8
2.0	ER2M020	570	82-178	179-305			0.8
2.5	ER2M025	620	82-178	179-305			1.0
3.0	ER2M030	765	82-178	179-305			1.0
5.0	ER2M050	840	100-178	179-305			1.8

*Applicable to both single and dual speed models 10 meter power supply cable (plug not included) with cable trolleys.



Hoists



Permanent Magnet Lifter

The Permanent Magnetic Lifter is a new concept product for lifting and handling steel plate, pipes, beams and cylindrical work pieces of ferromagnetic materials. Our Magnetic Lifters contain a NdFeB permanent magnet, which can generate high holding-power in a magnetic circuit.

With the use of a magnetic lifter the need for slings, clamps and special lifting frames can be eliminated. They are compact in design and construction, convenient in operation with a strong holding force, and are safe and reliable. These magnetic lifters are widely used for lifting and hoisting in factories, warehouses, wharves and transport facilities.

Features

- › Due to the high magnetic properties of the magnetic lifter the relevant size of the unit is smaller compared to other products with the same lifting capacity.
- › As the magnetic lifter is not electrically operated, accidents due to sudden power failure are avoided, the magnetic lifter can also be used outdoors or on site without the need for a power supply.
- › There are 'V' slots incorporated into the holding face allowing it to be used to lift pipes or round bar work pieces.
- › The special safety locking mechanism on the handle prevents the magnetic lifter from accidentally being released.
- › The magnetic lifter comes complete with a rated shackle that is stamped with the Working Load Limit (W.L.L.); Test No.; Serial No.; Month and Year of manufacture and the European standard compliance mark (CE).
- › Magnetic lifters are individually Proof Tested to twice their rated capacity for flat steel plate.



Hoists

Permanent Magnet Lifters



Complies to AS4991

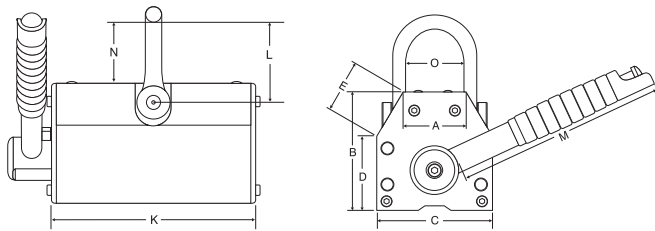

Product Code	Model Number	Rated Capacity Flat Plate WLL (kg)	Rated Capacity Cylinder WLL (kg)	Weight (kg)	A (mm)	B (mm)	C (mm)	D (mm)	E (mm)	K (mm)	L (mm)	M (mm)	N (mm)	O (mm)	Max Handle Turning Force
262010	BML-010	100	30	3	28	68	62	44	28	92	50	116	42	31	<4
262030	BML-030	300	100	10	44	93	92	59	39	164	75	142	59	46	<8
262060	BML-060	600	200	24	56	118	122	70	44	234	110	178	87	58	<8
262100	BML-100	1000	300	50	88	164	172	100	68	264	137	237	110	95	<16
262200	BML-200	2000	600	125	115	214	230	135	98	380	192	397	150	117	<16

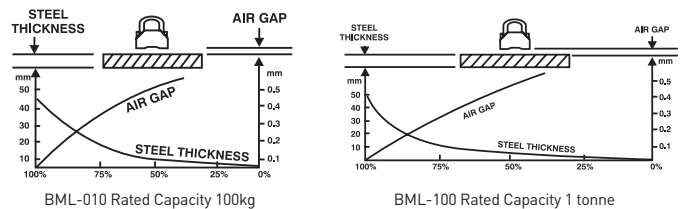

Steel Thickness and Air Gap Charts

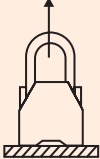
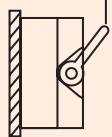

Rated Lifting Capacities

Model	Product Code	Horizontal	Vertical	Cylindrical
				
BML-010	262010	100kg	30kg	30kg
BML-030	262030	300kg	100kg	100kg
BML-060	262060	600kg	200kg	200kg
BML-100	262100	1 tonne	300kg	300kg
BML-200	262200	2 tonne	600kg	600kg

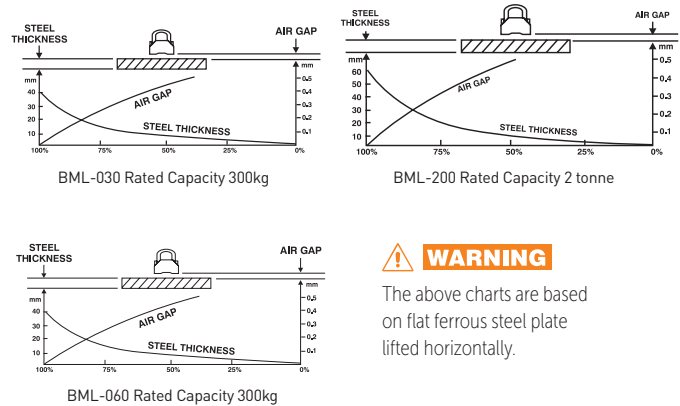

WARNING

The above charts are based on flat ferrous steel plate lifted horizontally.

Working temperature -40°C to 80°C

WARNING

The above table is based on flat ferrous steel and must be read in conjunction with Steel Thickness and Air Gap Charts opposite.



Hoists

Pneumatic Hoists

Capacities: 250kg to 15 tonne

Robust Construction Suitable for Underground Use. Complies to AS1418.2



Product Code	577200	577300	577600	577700
Rated Capacity (kg)	2000	3000	6000	10000
Control Type	Pull Cord	Pull Cord	Pull Cord	Pull Cord
Lift Height (m)	3	3	3	3
Full Load Lift Speed (m/min)	2.7	3.6	1.8	1.2
No Load Lifting Speed (m/min)	6.3	9.8	5	3.2
Full Load Lowering Speed (m/min)	4.9	6.5	3.3	2.1
No Load Lowering Speed (m/min)	3.5	5.5	2.8	1.8
Chain Falls	1	1	2	3
Air Consumption (m ³ /min)	2.8	4	4	4
Load Chain Size (mm)	9.5	11.1	11.1	11.1
A (mm)	210	210	210	387
B (mm)	312	371	371	371
C (mm)	305	295	295	295
D (mm)	520	500	-	-
E (mm)	610	600	-	-
F (mm)	-	-	660	747
G (mm)	-	-	760	871
Weight Without Chain (kg)	43	55	60	90
UOM	Each	Each	Each	Each

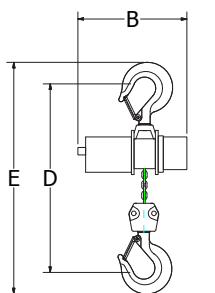
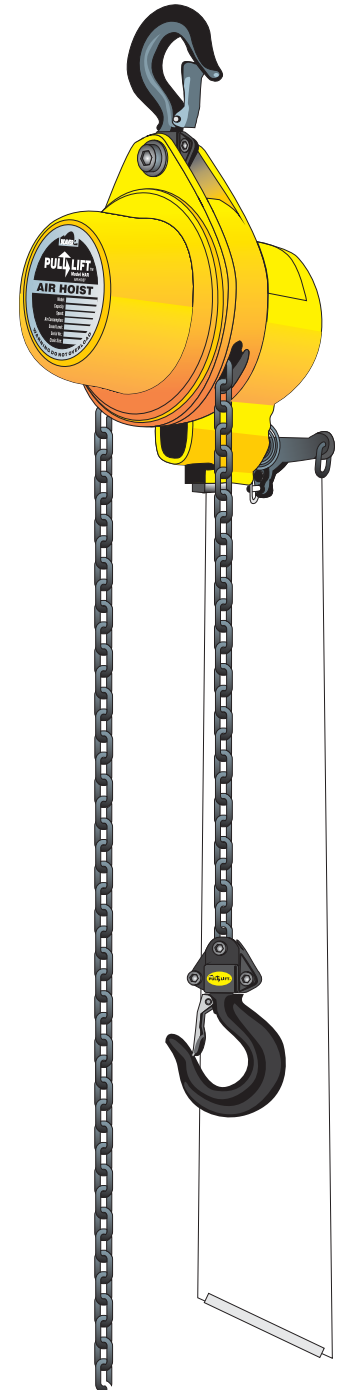

2 AND 3 TONNE

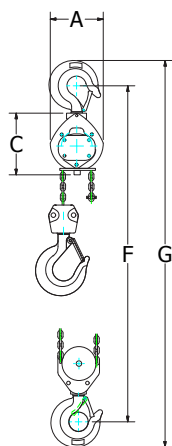

6 TONNE

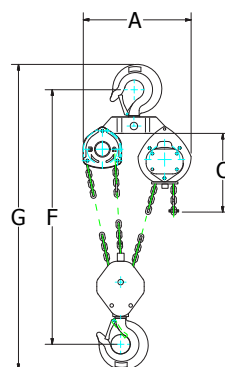

10 TONNE

Hoists

JDN Air Hoists

Capacities: 250kg to 20 tonne

JDN Air Hoists are ideal for tough industrial applications. The product's explosion protection is an important advantage for applications in hazardous areas. Manufactured to AS1418.2

Features

- › Patented pre-lube motor design for low maintenance, oil-free operation.
- › 100% duty rating and unlimited duty cycle suits all environmental conditions.
- › Only six atmospheres of compressed air required.
- › Insensitive to dust, humidity and temperatures ranging from -20 °C up to + 70 °C.
- › ATEX-approved models available, suitable for application in dangerous and explosive environments
- › Self-cooling economic air motor.
- › Fail-safe brake.
- › From 1 tonne upwards available with overload protection.
- › Low decibel rating.
- › F-type sensitive infinitely variable speed control for the precise positioning of loads.
- › Cord Control or Brass Pendant Control available, as well as an electro pneumatic interface for Radio Remote control as an option.
- › Easy operation and low maintenance.



Product Code	JDN705	JDN706	JDN715	JDN719	JDN725	JDN735
Model	0.25Ti	0.5Ti	1Ti	1.5Ti	2Ti	3Ti
Rated Capacity (t)	0.25	0.5	1	1.6	2	3.2
Weight with standard 3m lift (m)	27	27	28	56	34	86
Motor Power (kW)	1.0	1.0	1.0	1.3-2	1.0	3.5
Chain Dimension (mm)	7 x 21	7 x 21	7 x 21	9 x 27	7 x 214	13 x 36
Air Pressure (bar)	6	6	6	4-6	6	6
Air Consumption at full load (m ³ /min)						
Lifting	1.2	1.2	1.2	1.5-2.6	1.2	4
Lowering	1.5	1.5	1.5	2.2-3.6	1.5	5.5
Air Connection	G½	G½	G½	G¾	G½	G¾
Lifting Speed at full load (m/min)	20	11	5.5	4-6	2.7	5
Lowering Speed at full load (m/min)	38	17	11	11-12	5.5	10.8

Product Code	JDN732	JDN765	JDN775	JDN785	JDN795
Model	3Ti/2	6Ti	10Ti	16Ti	20Ti
Rated Capacity (t)	3.2	6.3	10	16	20
Weight with standard 3m lift (m)	66	110	156	240	285
Motor Power (kW)	1.3-2	3.5	3.5	3.5	3.5
Chain Dimension (mm)	9 x 27	13 x 36	16 x 45	16 x 45	16 x 45
Air Pressure (bar)	4-6	6	6	6	6
Air Consumption at full load (m ³ /min)					
Lifting	1.5-2.6	4	4	4	4
Lowering	2.2-3.6	5.5	5.5	5.5	5.5
Air Connection	G¾	G¾	G¾	G¾	G¾
Lifting Speed at full load (m/min)	2-3	2.5	1.6	1	0.7
Lowering speed at full load (m/min)	5.5-6	5.4	3.4	2.1	1.6

Hoists

Dimensions (in mm)

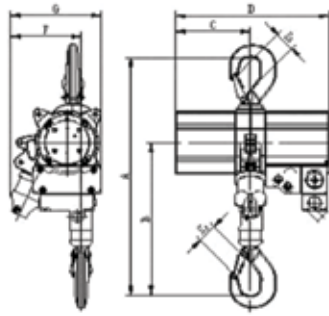

PROFI 0.25Ti - 2Ti

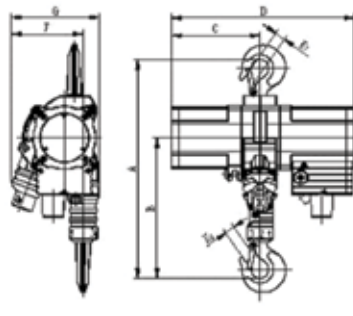

PROFI 1.5Ti - 3Ti/2

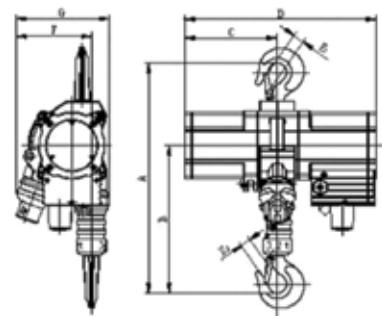

PROFI 3Ti / 20Ti

Model	0.25Ti	0.5Ti	1Ti	1.5Ti	2Ti	3Ti	3Ti/2	6Ti	10Ti	16Ti	20Ti
A (min. headroom ³) (mm)	450	450	450	480	498	593	544	674	813	898	1030
B (mm)	288	288	288	293	336	373	356	454	548	598	670
C (mm)	145	145	145	200	145	233	200	233	308	382	382
D (mm)	297	297	297	412	297	483	412	483	575	692	692
E ₁ (mm)	28	28	28	28	28	40	28	40	44	53	75
E ₂ (mm)	28	28	28	26	28	30	28	40	44	53	75
G (mm)	176	176	176	215	183	233	215	233	306	308	315
F (up to hook centre) (mm)	137	137	137	170	137	187	140	154	197	199	180

Hoists

JDN Mini Air Hoists

Capacities: 125kg to 980kg

The JDN Mini Series widens the range of applications in the light duty sector as a handy, flexible and light-weight hoist. The optional Mini Manipulator can be used to lift, lower, traverse and position loads in an easy, manual manner. The carrying capacities vary from 125kg to 980kg. Complies to AS1418.2.

Features

- › Patented pre-lube motor design for low maintenance, oil-free operation.
- › 100% duty rating and unlimited duty cycle suits all environmental conditions.
- › Only six atmospheres of compressed air required.
- › Insensitive to dust, humidity and temperatures ranging from -20 °C up to + 70 °C.
- › ATEX–approved models available, suitable for application in dangerous and explosive environments.
- › Also suitable for horizontal pulling.
- › Self-cooling economic air motor.
- › Fail-safe brake.
- › Wear resistant motor braking system.
- › Extremely sensitive lever control with emergency shut-off valve; maximum control length is 6 metres.
- › Easy operation and low maintenance.



Product Code	JDN123	JDN253	JDN503	JDN603
Model	MINI125	MINI250	MINI500	MINI1000
Rated Capacity (kg)	125	250	500	980
Weight with standard 3 m lift (kg)	9.5	10.5	21	23
Motor Output (kW)	0.4	0.4	1	1
Chain Dimensions (mm)	4 x 12	4 x 12	7 x 21	7 x 21
Air Pressure (bar)	6	6	6	6
Air Consumption at full load (m ³ /min)				
Lifting	0.5	0.5	1.2	1.2
Lowering	0.7	0.7	1.6	1.6
Air Connection	G ³ / ₈	G ³ / ₈	G ¹ / ₂	G ¹ / ₂
Lifting speed at full load (m/min)	15	8	10	5
Lowering speed at full load (m/min)	30	16	18	10

* Custom lift heights available. Weight and headroom based on mini standard model with pendant control and chain bucket.

** Pneumatic trolleys and cord controls not available for this range.

Dimensions in mm

MODEL	MINI125	MINI250	MINI500	MINI1000
A (mm)	328	328	458	458
B (mm)	232	232	316	316
C (mm)	367	367	505	505
D (mm)	92	92	122	122
E (mm)	213	213	292	292
F (mm)	109	109	148	148
G (mm)	104	104	144	144
H (mm)	177	177	234	234
J (mm)	148	148	194	194
K (mm)	83	83	119	119
L (mm)	29	29	40	40
M (mm)	19	19	28	28

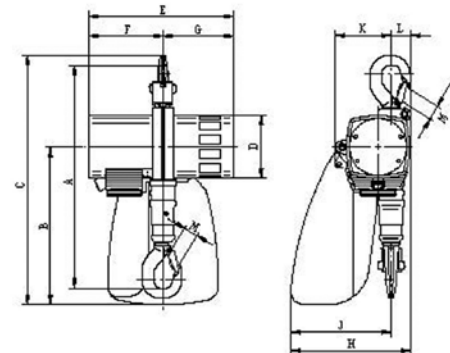

Hoists

JDN Mining Air Hoists

Capacities: 1 tonne to 6 tonne

The JDN M-series air hoists are specifically designed for underground mining operations where loads can be lifted, lowered and horizontally pulled. Due to their versatility, they are also suitable for many different industrial applications. The M-series have the same features as the JDN PROFI-series, however; they operate with an air pressure of only 4 bar. Complies with AS1418.2.

Features

- › Patented pre-lube motor design for low maintenance, oil-free operation.
- › 100% duty rating and unlimited duty cycle suits all environmental conditions.
- › Insensitive to dust, humidity and temperatures ranging from -20 °C up to + 70 °C.
- › ATEX-approved models available, suitable for application in dangerous and explosive environments.
- › Fail-safe brake, in case of air supply failure.
- › Cast iron housing suitable for severe conditions.
- › Easy operation and low maintenance design.
- › Two chain falls for operation in both directions.
- › Specially designed for horizontal and vertical moving of loads.

Product Code	JDN991	JDN990
Model	M64	M63D
Rated Capacity (t)	1-2	3-6
Weight with standard 3m lift (kg)	60	100
Motor Output (kW)	0.77	1.3
Chain Dimension (mm)	9 x 27	13 x 36
Air Pressure (bar)	4	4
Air Consumption at full load (m ³ /min)		
Lifting	1.0	2.2
Lowering	2.0	3.2
Air Connection	Rd 32 x 1/8"	Rd 32 x 1/8"
Lifting speed at full load (m/min)	3-1.5	2.2-1.1
Lowering speed at full load (m/min)	12.5-6.5	6-3

* Custom lift heights available. Weight based on standard model. Lifting speed at 2 m length of control. Longer control hoses decrease the lifting speeds

Dimensions in mm

Model	M64	M63D
A1 (smallest headroom with 1/1 chain strands) (mm)	603	750
A2 (smallest headroom with 1/2 chain strands) (mm)	660	870
B1 (with 1/1 chain strands) (mm)	313	370
B2 (with 1/2 chain strands) (mm)	370	490
C (mm)	175	237
D (mm)	375	507
E ₁ (Hook opening) (mm)	30	40
E ₂ (Hook opening) (mm)	30	40
E ₃ (Hook opening) (mm)	30	30
F (maximum width) (mm)	144	195



Pacific Hoists
QUALITY LIFTING SOLUTIONS

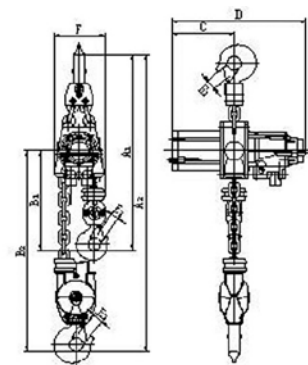

Hoists

PWB ANCHOR Air Hoists



Capacities: 500kg to 6 tonne

Suitable for use in hazardous environments, PWB Anchor Air Hoists are fitted with rotary vane motors to ensure compactness and durability in a variety of industrial and construction applications. Available in high and low speed models with cord or pendant controls.

Pendant	Product Code		Capacity (t)	Model	Lift Speed (m/mm)	Chain Falls	Headroom (mm)
	Pull Cord						
49251	49250		0.5	EHL05TS	10.5	1	365
49253	49252		1.0	EHL1TW	5.2	2	440
48236	48237		1.0	EHL1TS	6.0	1	480
48238	48239		2.0	EHL2TW	3.0	2	540
44181	44998		3.0	EHL3TS	3.0	1	585
47609	45000		6.0	EHL6TW	1.5	2	770

NOTE: Maximum recommended pendant length 8m. Part numbers shown for standard lift models (3 metres), optional lift heights available.



Hoists

TOKU Air Hoists



Capacities: 250kg to 25 tonne*

Toku Air Hoists come in standard models up 6000kg with larger capacity 10 and 25 tonne versions available to order. The air hoists offer smooth operation and are compact and lightweight for their capacities. Available with either cord or pendant control. Standard chain fall is 3metres, with other lengths to special order.

TOKU TCR Air Hoist 250 6000kg

Features

- › Overload protection including auto-stop on all units (except TCR-250 models).
- › Limit stop prevents over-travelling of hook when the load hook reaches either highest or lowest points.
- › Failsafe mechanism ensures load cannot fall as a result of power loss.
- › Improved and strengthened cast iron housing provides durability and reliability.
- › 100% duty cycle, flame/explosion proof motor.



Product Code/Model	Lifting Capacity (kg)	No. of Chain Falls	Lifting Speed				Weight with 3M lift chain (kg)	W/O Chain (kg)	Min Hook Distance (mm)	Chain Dimension (mm)	Hose size (mm)
			Load (up) (m/min)	Air Cons (m ³ /min)	Load (Down) (m/min)	Air Cons (m ³ /min)					
TCS-250P	250	1	34.0	1.7	63.0	2.0	19.0	16.0	414	6.3 x 19	12.7
TCS-250C	250	1	34.0	1.7	63.0	2.0	18.0	15.0	414	6.3 x 19	12.7
TCS-500P	490	1	17.0	1.7	34.0	2.0	19.0	16.0	414	6.3 x 19	12.7
TCS-500C	490	1	17.0	1.7	34.0	2.0	18.0	15.0	414	6.3 x 19	12.7
TCS-1000P2	990	2	8.5	1.7	17.0	2.0	25.0	19.0	456	6.3 x 19	12.7
TCS-1000C2	990	2	8.5	1.7	17.0	2.0	24.0	18.0	456	6.3 x 19	12.7

Note: Standard Lift for all above models is 3m. Operating Air pressure is 0.6Mpa

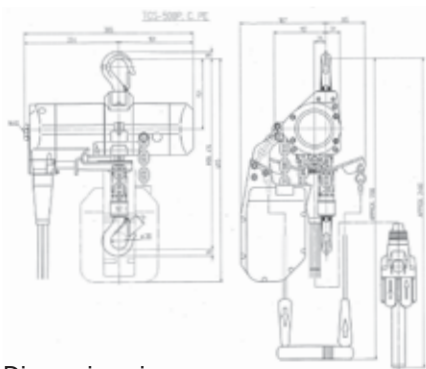

Dimensions in mm

Model	A (mm)	B (mm)	C (mm)	D (mm)	E (mm)	F (mm)	G (mm)	H (mm)	I (mm)	J (mm)	K (mm)	L (mm)	M (mm)	N (mm)	O (mm)
TCS-250P	365	161	204	151	414	555	15	25	112	31	25	85	197	-	2480
TCS-250PE	365	161	204	151	414	555	15	25	112	31	25	85	197	-	2480
TCS-250C	365	161	204	151	414	555	15	25	112	31	25	85	197	1700	-
TCS-500P	365	161	204	151	414	555	15	25	112	31	25	85	197	-	2480
TCS-500PE	365	161	204	151	414	555	15	25	112	31	25	85	197	-	2480
TCS-500C	365	161	204	151	414	555	15	25	112	31	25	85	197	1700	-
TCS-1000P	365	161	204	173	456	577	29.5	29	136	37	49	70	221	-	2500
TCS-1000P2E	365	161	204	173	456	577	29.5	29	136	37	49	70	221	-	2500
TCS-1000C	365	161	204	173	456	577	29.5	29	136	37	49	70	221	1720	-

Hoists

TOKU TMTCR Trolley Air Hoist Series 500-6000 kg



Features

- › Solid construction with all steel/casting construction.
- › Durability – The 4 Flageless wheels and 2 drive wheels allow low friction and smooth stopping operation, whilst providing excellent performance.
- › Automatic Brake – which does not require preliminary adjustment.
- › 100% duty cycle, flame/explosion proof motor.

Product Code/Model	TMTCR-500P			TMTCR-1000P2			TMTCR-1000P			TMTCR-2000P2			TMTCR-3000P			TMTCR-6000P2		
Trolley Model	TMTNC-1			TMTNC-1			TMTNC-1			TMTNC-3			TMTNC-3			TMTNC-6		
Lifting Capacity (kg)	500			1000			1000			2000			3000			6000		
Weight (W/O Chain) (kg)	79			79.5			83			97			125			157.5		
Air Consumption (m ³ /min)	1.5			1.5			1.5			1.5			2			2		
Travelling Speed (W/O Load) (m/min)	20			20			20			20			20			20		
Applied Beam Size (mm)	75	100	125	75	100	125	75	100	125	100	125	150	100	125	150	125	150	175
Min. Radius of Beam (mm)	3500	800	800	3500	800	800	3500	800	800	1300	800	800	1300	800	800	2000	2000	2000

External Dimensions

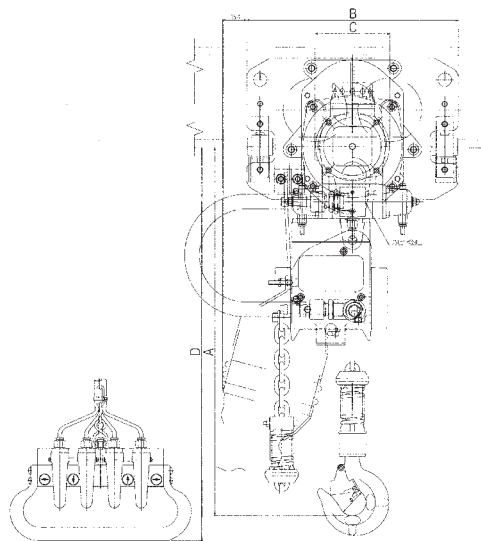
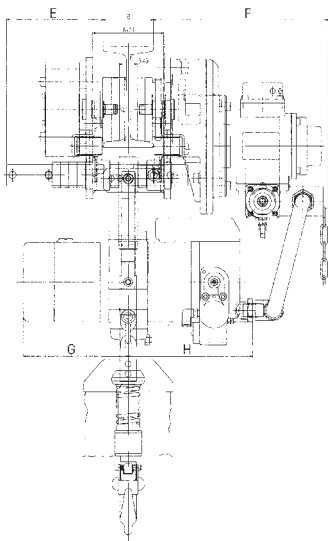

Dimensions in mm

Model	A (mm)	B (mm)	C (mm)	D (mm)	E (mm)	F (mm)	G (mm)	H (mm)
TMTCR-500P	490	315	111	2240	144	261	156	186
TMTCR-1000P2	497	315	111.3	2250	143.7	252.5	156	164.5
TMTCR-1000P	446	315	111.3	2250	143.7	252.5	156	164.5
TMTCR-2000P2	592	340	140	2240	163	266	156	186
TMTCR-3000P	554	340	140	2240	163	266	202	247
TMTCR-6000P2	660	400	156	2240	193	276	202	247

Winches



Electric Pull Lift Winch

Features

- › Power Transmission is via a direct coupling, to ensure low power loss and accurate speed control.
- › The unique braking system is designed for both static and dynamic loading. Large friction area brake discs for greater efficiency will automatically apply in the event of power loss. Our design means no adjustment of the brake is necessary.
- › The gearbox housing is a one piece casting, to ensure maximum durability and resistance to wear.
- › Planetary Gears – Compact design for better load sharing and reduction of the winch's overall weight. The gears are machined to provide long life and low operating noise.
- › The steel main drive gear provides maximum strength and increased life.
- › Sealed grease filled bearings fitted are lubricated for the life of the bearing.
- › Introduction type motor fitted for increased life, efficient operation and low noise output.
- › The connection of the wire rope to the winch drum is via set screw, to ensure rope retention.



Winches



Electric Winches 240v 50Hz (Single Phase models)

Robust Construction Suitable for Building Sites, Slipways & Industrial Use c/w 24 Volt IP65 Pendant Control with Emergency Stop

Product Code	Rated Capacity (kg)	Speed (m/min)	Motor Power (HP)	% ED	Effective Pull Height (m)	Wire Rope Dia. x Length (mm)	A (mm)	B (mm)	C (mm)	D (mm)	E (mm)	F (mm)	Weight Each (kg)
BPL1020	200	10-15	0.8	25	29	6 x 30	4 x 10.5D	142	142	510	210	246	36
BPL1025	250	10-15	1.0	25	29	6 x 30	4 x 10.5D	142	142	525	210	246	40
BPL1030	300	10-15	1.5	25	29	7 x 30	4 x 10.5D	172	142	540	210	246	49

Electric Winches 415v 50Hz (Three Phase models)

Robust Construction Suitable for Building Sites, Slipways & Industrial Use. c/w 24 Volt IP65 Pendant Control with Emergency Stop

Product Code	Rated Capacity (kg)	Speed (m/min)	Motor Power (HP)	% ED	Effective Pull Height (m)	Wire Rope Dia. x Length (mm)	A (mm)	B (mm)	C (mm)	D (mm)	E (mm)	F (mm)	Weight Each (kg)
BPL3030	300	10-15	1.5	25	29	7 x 30	4 x 10.5D	172	142	548	210	246	48
BPL3050	500	12-18	2.5	25	58	9 x 60	4 x 10.5D	400	330	922	372	430	136
BPL3075	750	12-18	3.5	25	58	9 x 60	4 x 10.5D	400	330	935	372	430	149
BPL3100	1000	12-18	5.0	25	58	11 x 60	4 x 10.5D	400	330	935	372	430	156
BPL3220	2200	7-12.5	7.5	25	97	16 x 100	4 x 12D	600	499	1160	565	658	450
BPL3350	3500	6.3-8.8	7.5	25	97	18 x 120	8 x 30D	847	680	1431	740	860	860

Single Phase Model

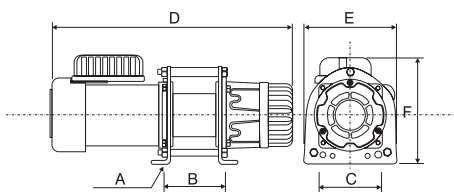

Three Phase Model

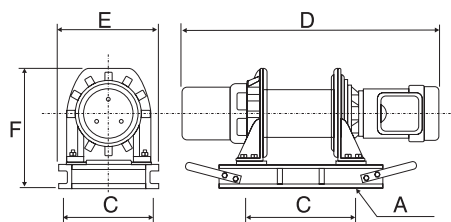

Winches



Electric Mini Hoist 240v 50Hz (Single Phase model)

Robust Construction Suitable for Building Sites

Product Code	Rated Capacity (kg)	Speed (m/min)	Lifting Height Size (m)	Hoist Motor Single Phase						
				Motor Power (HP)	Input Power (W)	% ED	Rope Dia. (mm)	Rope Construction	Grade of Rope	Weight Each (kg)
BMI1015	150	15	20	N/A	780	25	3.8	7 x 19	G1960min	28
BMI1025	250	12	20	N/A	1200	25	5.1	7 x 19	G1960min	30

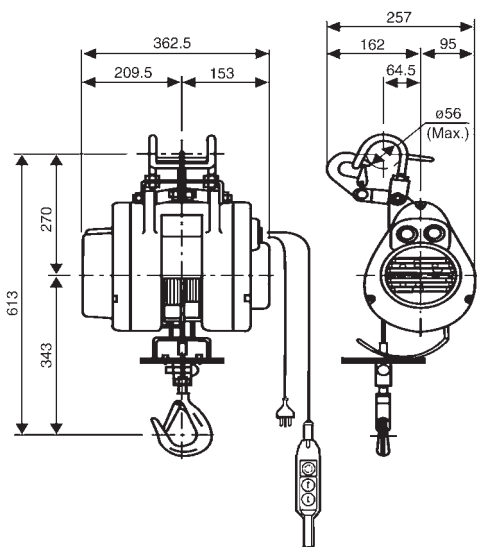

Mini Swivel Suspension Arm Scaffold Assembly

To suit Beaver Electric Mini Hoists. Affixes to scaffolding.

Product Code	Rated Capacity (kg)	Arm Length (mm)
BMI1025S	250	1015



Comeup Electric Winches

Capacities: 200kg to 5 tonne

Features

- › Lightweight and compact design for easy installation and portable use.
- › Electromagnetic spring-applied failsafe brake designed for both static and dynamic loading. Applies automatically in the event of power loss.
- › IP65 pendant control.
- › 4V push button control supplied as standard with all CP and CWG models.
- › Compact load sharing design of the heat-treated planetary gear ensures quiet operation and long life.
- › Emergency stop function switch is featured on all models.



Pacific Hoists
QUALITY LIFTING SOLUTIONS



CWL Range



CP Range



CWG Range

Winches



CWL Range

Product Code	CWL200	CWL200L	CWL305
Model	CWL200	CWL200L	CWL301L
Rated Capacity (kg)	200	200	300
Lifting Speed (m/min)	11-16	11-16	16-25
Phase Voltage	240 x 1	240 x 1	240 x 1
Wire Rope (ø mm x m)	5 x 46	5 x 71	6 x 60
Max. Lifting Height (m)	45	69	58
Net Weight (kg)	30	33	40

CP Range

Product Code	ACW200	ACW250	ACW300	ACW305	ACW310
Model	CP200	CP250	CP300	CP 500	CP750T
Rated Capacity (kg)	200	250	300	500	750
Lifting Speed (m/min)	10-15	10-15	10-15	10-15	10-15
Phase Voltage	240 x 1	240 x 1	240 x 1	240 x 1	415 x 3
Wire Rope (ø mm x m)	6 x 30	6 x 30	6 x 30	7 x 60	9 x 60
Max. Lifting Height (m)	29	29	29	58	58
Net Weight (kg)	32	34	38	55	135

CWG Range

Product Code	ACW320	ACW345	ACW330	ACW350	ACW340	ACW375	ACW565	ACW750	ACW800	ACW850
Model (CWG)	10077	30075	10151	30151	30265	30375	30565	30750	31500	34000
Rated Capacity (kg)	300	300	400	500	650	900	1100	2200	3500	5000
Lifting Speed (m/min)	12-19	10-15	12-18	12-18	12-18	13-20.6	14-25	6.9-12.6	5.8-8	8-12.2
Phase Voltage	240 x 1	415 x 3	240 x 1	415 x 3	415 x 3	415 x 3	415 x 3	415 x 3	415 x 3	415 x 3
Wire Rope (ø mm x m)	6 x 60	6 x 30	9 x 60	9 x 60	9 x 60	10 x 60	12 x 100	16 x 100	18 x 150	22.4 x 200
Max. Lifting Height (m)	58	29	58	58	58	58	97	97	144	192
Net Weight (kg)	42	32	120	120	154	185	250	400	800	1380

TOKU TAW Air Winch 300kg-2000kg



Capacities: 300kg to 2000kg

Lightweight, compact and simple placement in confined spaces is easily achieved. The all steel design provides years of trouble free operation. Units come standard with both internal automatic failsafe brake and manual band brake. Manufactured for rugged service and mining safety. Reliable in harsh environments such as heat, dust and humidity.

Features

- > Quick clutch allows the wire rope to be installed easily.
- > The spool valve controls the speed.
- > Dual brake system for added safety



Product Code/Model	Lifting Capacity (kg)	Air Pressure (MPa)	Rope Speed (m/min)	Air Cons (m ³ /min)	Weight (kg)	Wire Rope Dimension (mm x m)	Hose Size (mm)	Mounting Bolts (mm)
TAW-300B	300	0.4	20.0	2.7	42.5	6 x 48	19.0	M10 x 4
		0.5	23.8	3.0				
		0.6	27.0	3.4				
TAW-500	500	0.4	15.0	2.7	75	8x100	19.0	M12x4
		0.5	17.8	3.1				
		0.6	20.0	3.4				
TAW-1000	1,000	0.4	7.8	3.2	90	10 x 114	19.0	M12 x 6
		0.5	10	3.6				
		0.6	11.5	3.9				
TAW-1500A	1,500	0.4	5.9	3.2	90	12 x 60	19.0	M12 x 6
		0.5	7.3	3.7				
		0.6	8.5	4.1				
TAW-2000	2,000	0.4	4.3	4.1	130	16 x 63	19.0	M12 x 6
		0.5	5.2	4.5				
		0.6	5.7	4.9				

Winches

Hand Winches



Product Code/Model	Standard Finish	Stainless Steel Available	Pulling Capacity (kg)	Noiseless Available	Net. Weight (kg)	Lifting Capacity	Kylan Finish Available	Hub Diameter (mm)	Handle Length (mm)	Hand Force Required (kg)	Gear Ratio	Cable Diameter (mm)
BHW-1200	Powder-coated	Yes	545	Yes	3.3	270	Yes	Ø50	210	15	4.1 : 1	Ø4.8
BHW-1800	Powder-coated	Yes	820	No	8.0	410	Yes	Ø70	320	22	5.0 : 1	Ø6.4
BHW-2600	Powder-coated	Yes	1200	No	10.3	600	Yes	Ø80	320	19	10 : 1	Ø8.0

BHW1200

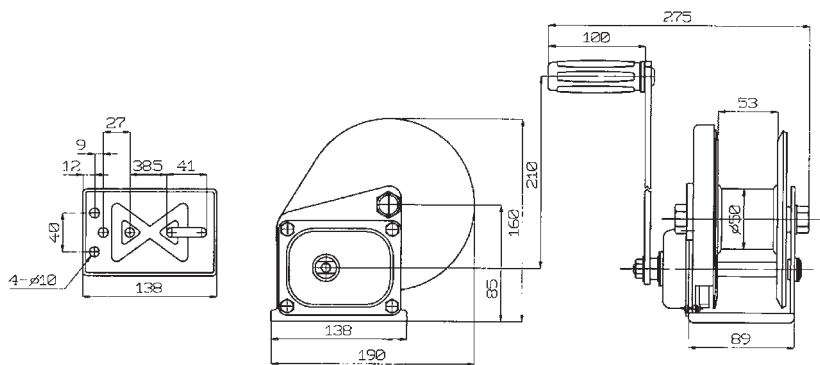

BHW1800

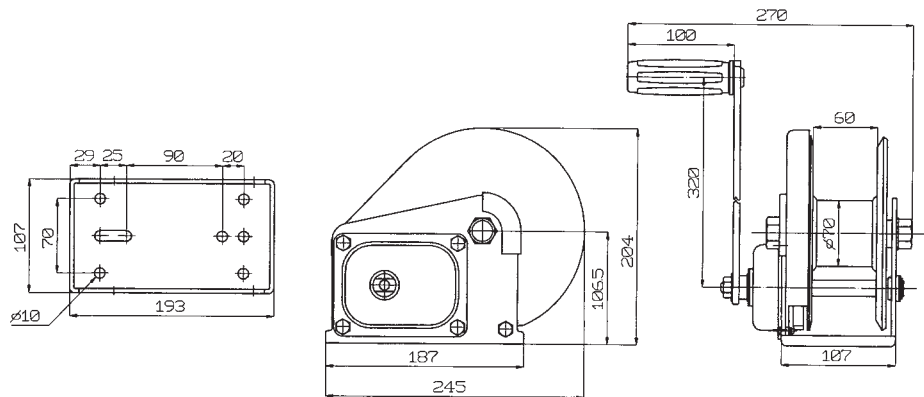

BHW2600

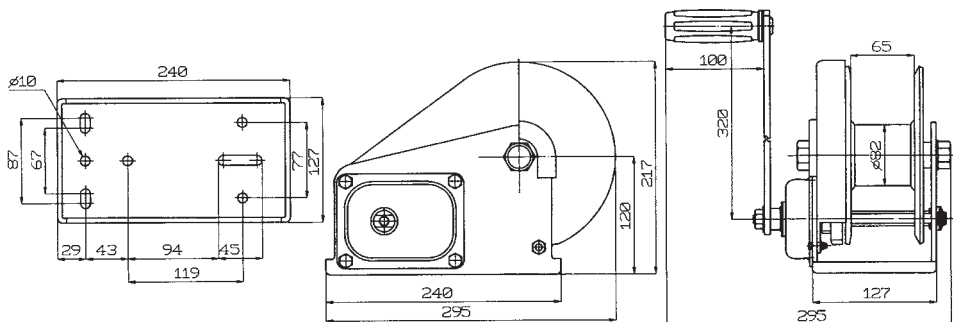
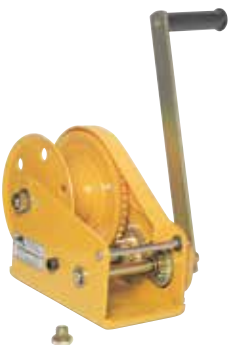

Winches

Industrial Heavy Duty Construction Winch

Suitable For Confined Spaces



Product Code/Model	Standard Finish	Stainless Steel Available	Pulling Capacity (kg)	Noiseless Available	Net. Weight (kg)	Lifting Capacity	Kylan Finish Available	Hub Diameter (mm)	Handle Length (mm)	Hand Force Required (kg)	Gear Ratio	Cable Diameter (mm)
SF-2200	Powder-coated	No	1700	No	13.5	850	No	Ø60	300	16	22.2 : 1	Ø6.4

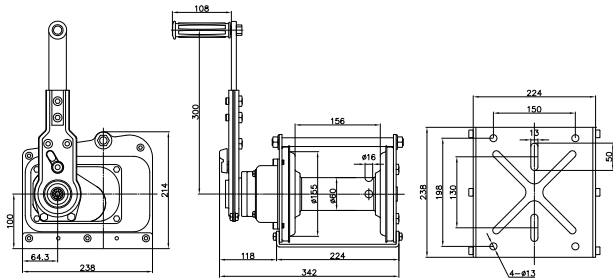

Worm Drive Winch

For Safe Controlled Movement of a Load

Product Code/Model	HW1500
Pulling Capacity (kg)	680
Lifting Capacity (kg)	340
Finish	Powder-coated
Gear Ratio	41.0 : 1
Handle Length (mm)	195
Hub Diameter (mm)	Ø48
Cable Diameter (mm)	Ø5.6
Net. Weight (kg)	5.0

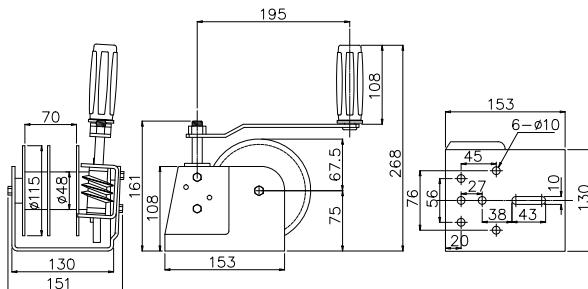

Winches

General Purpose Hand Winches



Product Code/ Model	Rated Capacity – Pulling (kg) (kN)	Rated Capacity – Hoisting (kg)	Max. Hand force required (kg)	Type of Brake	Gear ratio	Hub Diameter (mm)	Handle length (mm)	Unit weight – Bare (kg)	Wire Rope Diameter (mm)	Wire Rope construction	Grade of Wire Rope	Wire Rope finish	Wire Rope storage capacity (m)
517360	360	360	120	Gear	3.2:1	18	150	2.23	5	7 x 19	G1770 - G2070	HDG	10
517450	450	450	150	Gear	4.1:1	18	186.5	2.70	5	7 x 19	G1770 - G2070	HDG	20
517630	630	630	210	Gear	4.1:1	18	186.5	2.90	5	7 x 19	G1770 - G2070	HDG	20
517900	900	900	300	Gear	4.1:1 + 10:1	24	251.5	6.30	5	7 x 19	G1770 - G2070	HDG	20
517125	1125	1100	375	Gear	5.1:1 + 12.2:1	24	251.5	7.60	6	7 x 19	G1770 - G2070	HDG	25



General Purpose Winch Hooks Suitable for Wire & Webbing

Product Code/ Model	Capacity (kg)	d1 (mm)	b (mm)	e (mm)	g1 (mm)	Weight (kg)	UOM
426315	1500	18	44	66	13	0.17	Each

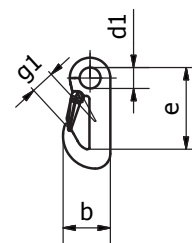

Digital Load Cells

Portable Aluminium In Line System with Radio Linked Digital Readout

The radio linked in line tension cell range is suited to all types of load monitoring, weighing, lifting, winching and towing where connection cables are not practical.

Load Cell Performance Specifications

- › High strength aircraft grade aluminium
- › Accuracy is better than 0.5% (typically 0.1% of range)
- › Safe overload 200% to 100t then 150%
- › Ultimate overload 500%
- › On/Off remotely, timed auto off
- › 2.4GHz carrier frequency (100m range – line of sight)
- › Battery life
 - Continuous > 40 hours (before recharge)
 - Typical usage > 3 months
 - Standby > 6 months

*For optimum accuracy and safety, shackle size must match cell capacity.

The cells from 2-120 tonnes are for grade S shackle sizes. Above 100 tonne are for grade T.



Capacity (kg)	A Length (mm)	B Width (mm)	C Plate thickness (mm)	D Hole Centres (mm)	E Hole Size (mm)	F Nominal weight (kg)
2,000	248	92	25	180	24	4
3,200	248	92	30	180	26	4
6,500	278	100	35	200	28	5
12,000	320	124	50	220	38	6
17,000	325	129	58	220	45	7
25,000	370	140	70	230	57	8
35,000	425	146	73	260	62	11
50,000	490	164	77	292	76	15
85,000	630	210	100	380	100	30
120,000	630	230	135	380	110	35*
150,000	688	250	148	388	118	40*
200,000	890	290	173	510	130	80*
250,000	890	295	198	555	145	90*

*Excludes carry case.

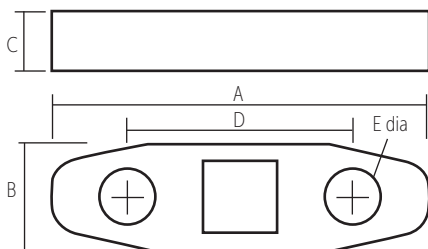

Materials Handling Equipment

Universal Plate Clamps

Model Type: UC Complies to AS 4991

Product Code	WLL (kg)	A Jaw Openings (mm)	B (mm)	E (mm)	C (mm)	D (mm)	UOM	Net Weight (kg)
261050	500	0 - 15	105	30	45	218	Each	2
261075	750	0 - 14	105	30	45	218	Each	2
261100	1000	0 - 20	145	48	63	305	Each	5
261200	2000	0 - 25	175	68	68	368	Each	7.5
268300	3000	0 - 28	218	74	90	395	Each	15.5
268500	5000	0 - 32	268	80	120	478	Each	22

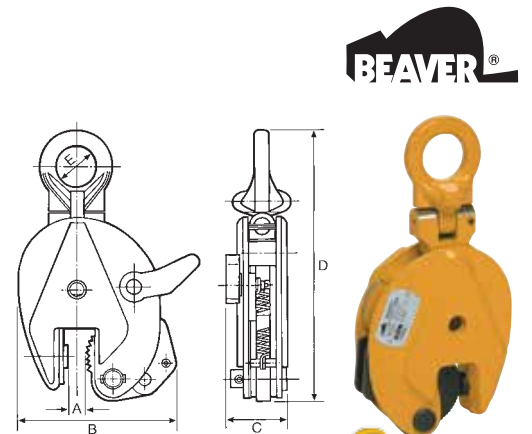

Non Marring (Non Marking) Plate Clamps for Stainless Steel

Complies to AS 4991 and approved

Product Code	WLL (kg)	Jaw Openings (mm)	W (mm)	L1 (mm)	L2 (mm)	D (mm)	H (mm)	Net Weight (kg)	UOM
267400	1500	0 - 20	41	203	297.5	48	275	6.6	Each

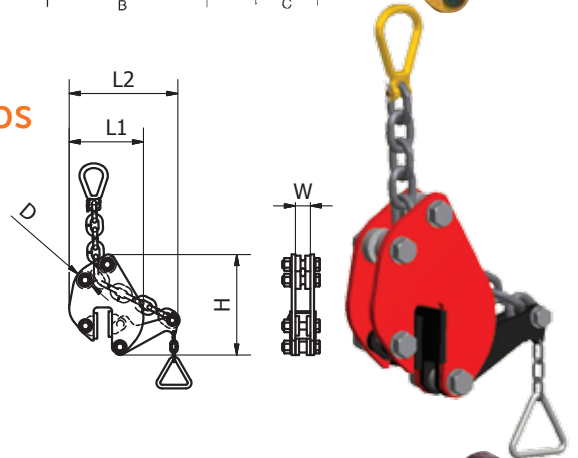

Horizontal Plate Clamps

Model Type: CQ Complies to AS 4991

Product Code	WLL per pair (kg)	Jaw Openings Max. (mm)	A (mm)	B Max. (mm)	C (mm)	D (mm)	E (mm)	Net Weight per pair (kg)
250150A	1500	0 - 50	0-50	127	100	218	30	8.2
250300A	3000	0 - 50	0-50	220	110	270	36	15
250500A	5000	0 - 60	0-60	260	130	315	40	27.6

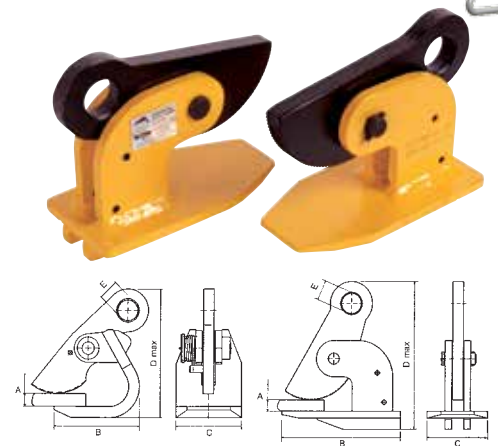

Vertical Plate Clamps

Model Type: VC Complies to AS 4991

Product Code	WLL (kg)	A Jaw Openings (mm)	B (mm)	C (mm)	D (mm)	E (mm)	Net Weight per pair (kg)
261130	1000	0-22	123	65	275	50	3.6
261240	2000	0-30	127	71	305	55	5
261350	3000	0-40	169	83	340	60	7.7
261560	5000	0-50	190	100	405	60	14.2

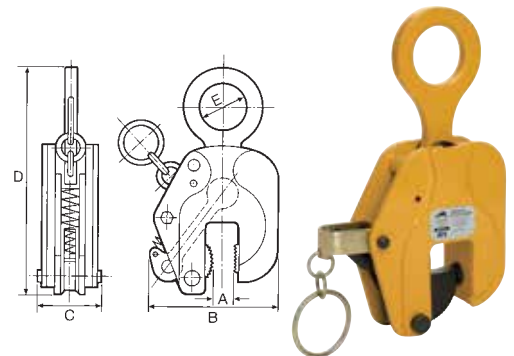

Materials Handling Equipment

PWB ANCHOR Multi Directional Lifting Clamps



Model Type: SBB complies to AS4991-2004

Product Code	Model	WLL (t)	Hardness Range	Effective thickness (mm)	Weight (kg)
44925	SBB-05	0.5	Hv 85-320	1-25	1.8
44926	SBB-1	1.0	Hv 85-320	1-40	4.0
44927	SBB-2	2.0	Hv 85-320	1-40	7.6
43497	SBB-3	3.0	Hv 85-320	5-35	8.3
43496	SBB-5	5.0	Hv 85-320	10-40	14.3



SBB

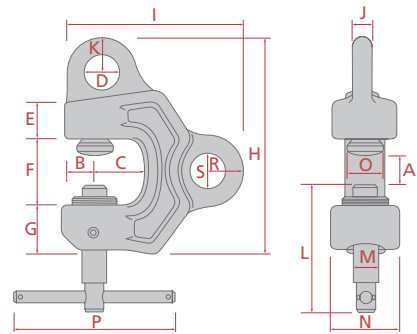

Measurement diagram for SSB and SSBA

Model Type: SBBA complies to AS4991-2004

Product Code	Model	WLL (t)	Hardness Range	Effective thickness (mm)	Weight (kg)
44932	SBBA-05	0.5	Hv 85-600	1-25	1.8
49600	SBBA-1	1.0	Hv 85-600	1-40	4.0
49601	SBBA-2	2.0	Hv 85-600	1-40	7.6
49602	SBBA-3	3.0	Hv 85-600	5-35	8.3



SBBA

Model	B (mm)	C (mm)	D (mm)	E (mm)	F (mm)	G (mm)	H (mm)	I (mm)	J (mm)	K (mm)	L (mm)	M (mm)	N (mm)	O (mm)	P (mm)	Q (mm)	R (mm)	S (mm)
SBB-05	23	25	27	22	41	29	140	112	15	24	96	20	46	26	150	15	24	27
SBB-1	30	45	32	31	61	46	203	166	18	34	124	24	55	36	150	22	34	32
SBB-2	37	43	36	44	66	46	218	185	25	38	134	32	74	44	150	25	36	32
SBB-3	40	47	45	40	60	60	240	170	30	43	137	36	80	50	150	30	30	31
SBB5	48	55	50	45	70	70	276	213	35	47	150	40	96	60	150	35	45	37
SBBA-05	23	25	27	22	41	29	140	223	15	24	96	20	46	26	150	15	24	27
SBBA-1	30	45	32	31	61	46	203	166	18	34	124	24	55	36	150	22	34	32
SSBA-2	37	43	36	43	66	45	210	183	25	38	134	32	70	44	150	25	36	32
SBBA-3	40	47	45	40	60	60	240	170	30	42	137	36	80	50	150	30	30	31

Materials Handling Equipment

Single Hand Operated Sheave Blocks with Swivel Hook

Designed for use on mobile, overhead and truck cranes

Product Code	G Sheave Dia. (mm)	Wire Dia. (mm)	Fibre Rope (mm)	B (mm)	D (mm)	WLL (kg)	UOM
550063	63	5	10	168	35	250	Each
550076	76	6	12	189	35	250	Each
550089	89	7	14	253	38	250	Each
550102	102	8	16	276	48	500	Each
550114	114	9	18	322	48	750	Each
550127	127	10	20	333	61	1000	Each
550152	152	12	24	380	71	1000	Each
550178	178	14	28	443	83	1500	Each
550203	203	16	32	500	94	2000	Each

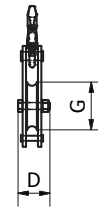
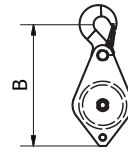

Double Sheave Blocks with Swivel Hook

Product Code	G Sheave Dia. (mm)	Wire Dia. (mm)	Fibre Rope (mm)	B (mm)	E (mm)	WLL (kg)	UOM
551063	63	5	10	168	59	250	Each
551076	76	6	12	189	59	250	Each
551089	89	7	14	253	64	250	Each
551102	102	8	16	276	79	500	Each
551114	114	9	18	322	79	750	Each
551127	127	10	20	333	95	1000	Each
551152	152	12	24	380	107	1500	Each

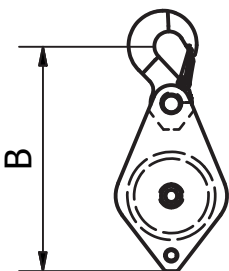
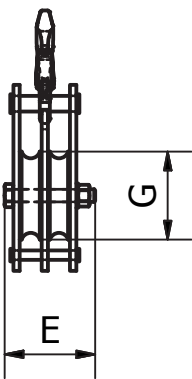



Heavy Duty Snatch Blocks

Beaver's new range of Heavy Duty Snatch Blocks offer the best in innovation, safety, reliability and performance with applications for construction mining, offshore exploration and the building industry.

- › Solid all-steel construction.
- › Easy opening mechanism ensures a fast change of wire rope while block is suspended.
- › Fully machined sheave.
- › Sheave has a sealed ball bearing system, fully lubricated for maintenance free operation.
- › Forged steel eye is designed to avoid twisting of unit during operation.
- › Fitted with grease nipples for ease of maintenance.
- › Special design of side plates restricts rope from jamming.
- › Beaver Heavy Duty Snatch Blocks are operationally tested to 2 times the Working Load Limit (W.L.L.) and come with an individual test certificate.
- › Each unit is supplied complete with Grade 'S' safety bow shackle to AS2741.
- › All Beaver Heavy Duty Snatch Blocks have an individual test serial number stamped on the identification plate.
- › Manufactured and tested to AS2089.

Super Snatch Blocks

C/W Grade "S" Safety Bow Shackle. Shackle Complies to AS2741

Product Code	WLL (t)	Wire Rope Dia. (mm)	Sheave Dia. F (mm)	A (mm)	B (mm)	C (mm)	D (mm)	E (mm)	Grade 'S' Safety Bow Shackle to AS2741
557210S	4000 3700	14 12	210	367	220	68	32	32	22 x 25mm
557275S	8000 6000	18 16	275	518	285	94	40	48	25 x 29mm
557395S	12000 12000	26 22	395	682	410	133.5	49	63.5	35 x 38mm
557420S	15000 15000	28 26	420	725	435	133.5	55	63.5	38 x 41mm
557480S	22000 20000	32 28	480	867	500	155	68	70	44 x 51mm
557675S	30000	44	675	1146	700	173.5	82	90	51 x 57mm
557750S	50000 50000	52 48	750	1435	780	235	100	105	63 x 70mm

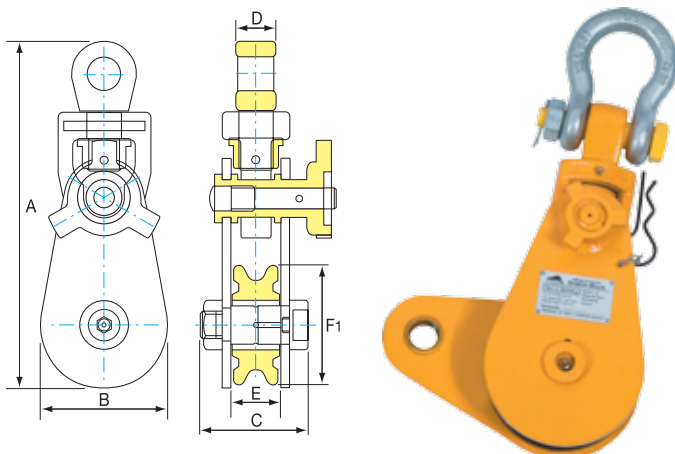

Materials Handling Equipment

Gunnebo Snatch Blocks



Gunnebo Johnson Snatch Blocks have the convenient side opening feature. This is true even of our heavy duty top dead-end models, and makes it easy to reeve the block without removing any fitting from the end of the wire rope. Other features include choice of swivel hook, shackle, eye fittings or Tailboard Blocks which have no fittings at all.

Standard Features

- › Rugged and reliable
- › 4:1 design factor
- › Easy-open side plates
- › Metric rated
- › Large hand nuts
- › Retainer on latch pin
- › Anchor shackle with retainer pin
- › Bronze bushing

Optional Features

- › Proof load
- › Roller bearings
- › Marine epoxy paint
- › Heavy duty J-latch
- › Larger sizes

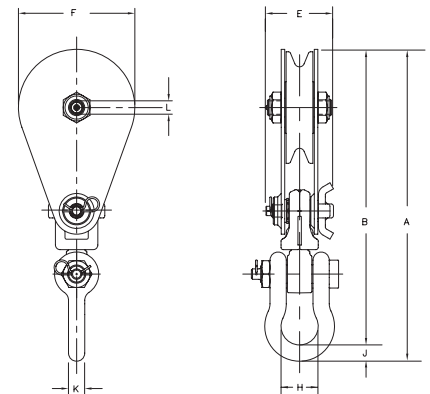

Product Code	Capacity WLL (t)	Standard Wire Rope Size (mm)	Max. Allow Optional (mm)	WT	A (mm)	B (mm)	E (mm)	F (mm)	H (mm)	J (mm)	K (mm)	L (mm)
SB 2S 3BS	2	8-10	10	2.3	251	239	69	81	32	13	11	19
SB 4S 4BS	4	10-13	16	7.3	373	351	92	121	51	22	22	25
SB 4S 6BS	4	10-13	16	9.5	428	406	92	159	51	22	22	25
SB 8S 6BS	8	16-20	22	13.2	487	462	102	158	59	25	25	38
SB 8S 8BS	8	16-20	22	16.8	538	513	102	209	59	25	25	38
SB 8S 10BS	8	16-20	22	19.5	589	563	102	260	59	25	25	38
SB 12S 10BS	12	20-22	28	33.6	656	624	123	260	73	32	32	51
SB 15S 14BS	15	20-22	28	48.2	757	725	123	362	73	32	32	64
SB 20S 16BS	20	14-28	28	73.2	934	893	148	412	102	41	41	57
SB 30S 20BS	30	32-36	36	134.5	1124	1083	147	514	102	41	41	89

Wire Rope Hoists



Beaver Tuff - Pull™ Wire Rope Hoists

Model Type TP -C/w 20m of Wire Rope.

Complies to AS1418.2* Compact Steel Housing (Orange)

Product Code	Rated Capacity Pulling (kg)	Rated Capacity Lifting (kg)	Wire Rope Dia. (mm)	Std Rope Length (m)	Rope advanced per full stroke cycle (mm)	Effort on handle at rated lifting capacity; Forward operation. (kN)	Nett weight Wire Rope and Reel (kg)	Nett weight without Wire Rope (kg)	A (mm)	B (mm)	C (mm)	D (mm)	E (mm)	F (mm)	X (mm)
519508	1250	800	8.3	20	≥52	343N	6.7	6.7	439	175	269	60	800	-	77.5
519516	2500	1600	11	20	≥55	441N	17	17	546	196	334	82	800	1200	90.5
519532	5000	3200	16	20	≥28	441N	29	29	685	241	389	110	800	1200	140

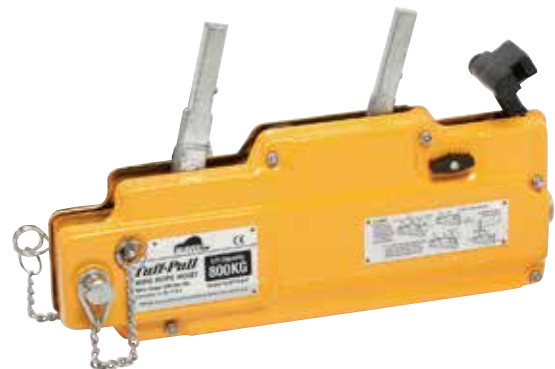
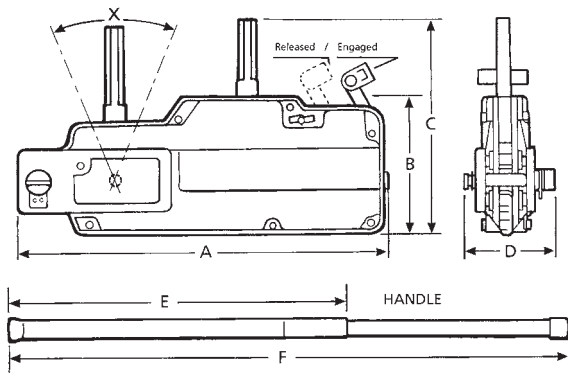

Materials Handling Equipment

Unilift Concrete Clutch / Locking Klaw



These strong, safe, lightweight clutches suit all spherical head lifting anchors. They protect against dangerous disconnection where there is a risk of fouling which is a common problem when lowering precast drainage products in confined spaces like trenches.

A higher working load limit for 1LK and 2LK Klaws compensates for sling angles as shown in the table below.

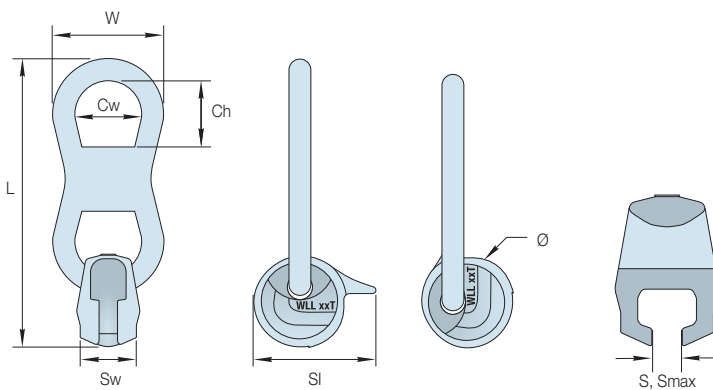

Working Load Limits

WLL (t) 0° Sling Angle	Annual Proof Load (kN)	Nominal WLL (t) Anchor	WLL (t) 60° Sling Angle	Product Code
2	24	1.3	1.7	01LK
3	36	2.5	2.6	02LK
5	60	5	4.3	05LK
10	120	10	8.6	10LK
20	240	20	17.2	20LK
32	384	32	27.6	32LC

Nominal Dimensions

Product Code	L (mm)	W (mm)	Ch (mm)	Cw (mm)	Sw (mm)	Sl (mm)	ø (mm)	S (mm)	Smax (mm)
01LK	170	66	44	40	33	72	56	11	13
02LK	215	85	59	52	42	88	68	16	18
05LK	270	110	62	70	57	113	88	22	25
10LK	365	145	83	90	73	144	112	31	32
20LK	515	210	103	130	110	196	152	43	46
32LC	680	272	189	172	160	300	180	52	58

A 5 tonne remote release Locking Klaw is also available which is ideal for Tilt-Up construction.

Product Description	Part Code
5 Tonne Remote Release	05LKRR

Railway Line Lifting Tong

Product Code	WLL (kg)	Weight (kg)	L1 min (mm)	L1 max (mm)	L2 min (mm)	L2 max (mm)	H min (mm)	H max (mm)	W (mm)	UOM
263150R	1500	7.5	0	80	190	220	265	180	26	Each

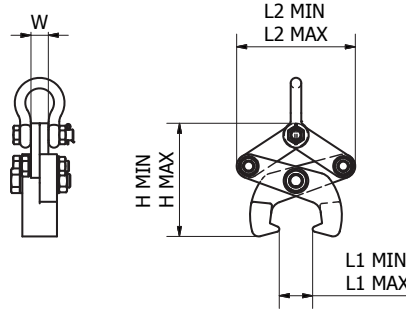

Drum Lifting Sling Assembly

Including oblong link, chain connectors, grade 80 alloy chain & Drum hooks. Intended for use with steel 205 Litre (ie. 44 gallon) drums in accordance with the diagram as displayed complying to Australian Standard for Chain Slings

Product Code	WLL (kg)	Grade 80 Chain (mm)	Chain Length (m)	E (mm)	W Drum Size (l)	Net Weight (kg)	UOM
B1155263507K	1000	7	2.5	1139	200	4.5	Each

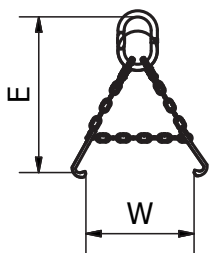

Materials Handling Equipment

Drum Hooks – Drop forged Grade 80 Heat treated, Painted Yellow



Complies to AS 3776 for Grade 80 Fittings

Product Code	WLL per pair (kg)	Grade 80 Chain (mm)	d (mm)	c (mm)	Net Weight per Pair (kg)	UOM
886840	2000	40397	40	165	1.8	Each

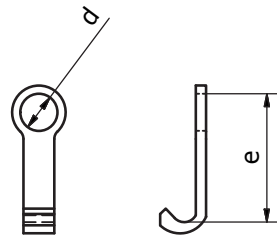

Vertical Drum Lifting Clamps

Complies to AS 4991

Product Code	WLL (t)	Type	L Drum Size (l)	H (mm)	Net Weight (kg)	UOM
262500	500	Vertical	200	470	5	Each

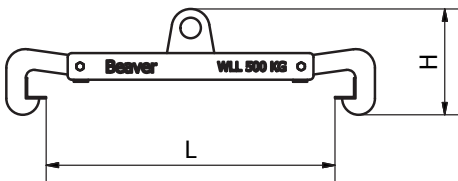

Horizontal Drum Lifting Clamps

Complies to AS 4991

Product Code	WLL (t)	Type	L Drum Size (l)	H (mm)	Net Weight (kg)	UOM
261500	500	Horizontal	200	152	7	Each

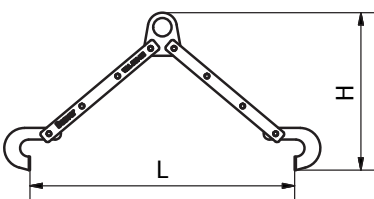

Pipe Lifting Lug & Bar

The Pipe Lifting Lug and Bar is designed for the lifting of concrete pipes via holes in the pipe walls. The lug is fed down through a hole in the pipe wall and the bar is positioned through the eye inside the pipe to secure the connection.

Manufactured and tested to AS4991 (NATA certificate issued)

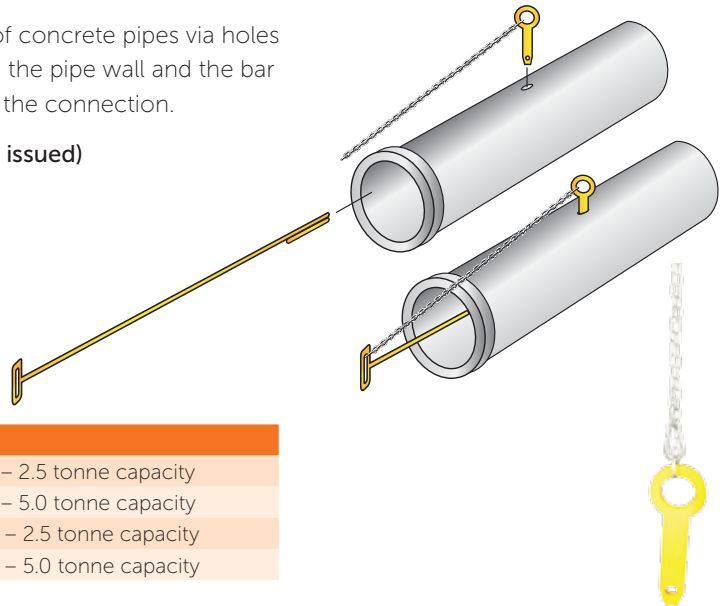

Product Code	Description
09960820	Pipe Lifting Bar – 2.5 tonne capacity
09960830	Pipe Lifting Bar – 5.0 tonne capacity
09960880	Pipe Lifting Lug – 2.5 tonne capacity
09960890	Pipe Lifting Lug – 5.0 tonne capacity

Pipe End Lifters

Robertsons Pipe End Lifters are designed for lifting pipes using a two legged chain sling. The hooks are designed so that at the correct sling angle, the forces generated work to keep the hooks in place.

- > Available in **2.5 tonne** and **5 tonne** capacities.
- > Supplied painted yellow (can be supplied hot dip galvanised if required).

Optional extras:

- > Handle on the rear for easy fitment.
- > Varying pad and bash pad configurations.

Manufactured and tested to AS4991 (NATA certificate issued)

Note: Please contact your local Robertsons branch for product code details and to place an order.



Materials Handling Equipment

Hand Pallet Trucks And Trolleys



Hand Pallet Trucks offer the ideal solution for transporting palletized goods easily and safely in warehouses, terminals, delivery/ receiving docks, storage and cool rooms.

Hand Pallet Trucks (Powder Coated Finish)

Complies to AS2615. Complete with PU Wheels

Product Code	342601
Model No.	BPT342601S
Capacity (kg)	2500
Min. Fork Height A (mm)	185
Min. Fork Height B (mm)	200 x 50
Steering Wheel S (mm)	74 x 93
Size of Fork F (mm)	177 x 45
Width Overall Forks D (mm)	685
Fork Length C (mm)	1220
Overall Length L (mm)	1563
Height of Backplate B (mm)	360
Overall Height H (mm)	1240
Nett Weight (kg)	89

Hand Pallet Trucks (Powder Coated Finish) with Brake

Complies to AS2615. Complete with
PU Wheels

Product Code	342601B
Model No.	BPT342601B
Capacity (kg)	2500
Min. Fork Height A (mm)	185
Min. Fork Height B (mm)	200 x 50
Steering Wheel S (mm)	74 x 93
Size of Fork F (mm)	177 x 45
Width Overall Forks D (mm)	685
Fork Length C (mm)	1220
Overall Length L (mm)	1563
Height of Backplate B (mm)	360
Overall Height H (mm)	1240
Nett Weight (kg)	94

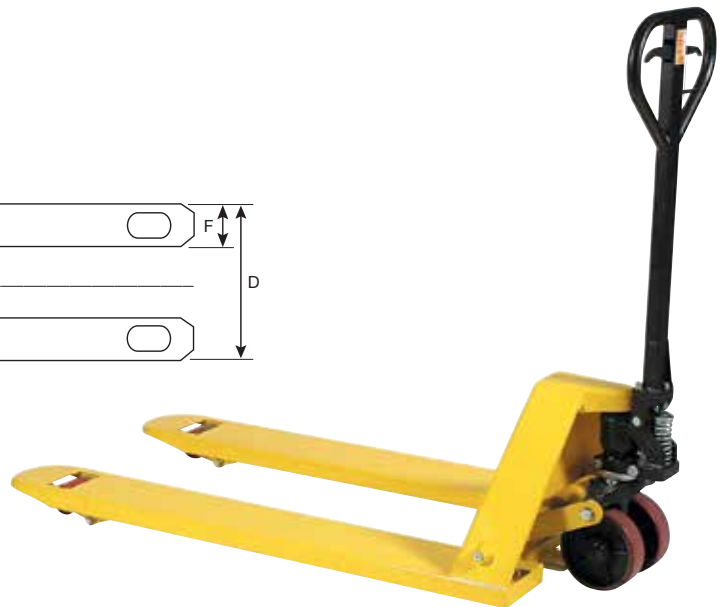
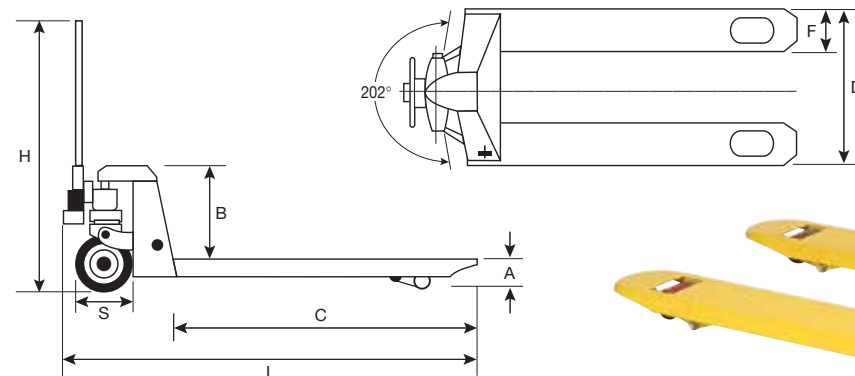

Materials Handling Equipment

LIFTPAL Hand Scissor Lift Tables have special applications for raising heavy loads with the use of hydraulics which increases safety and helps prevent back injuries. They are a safe and versatile way to transport goods in warehouses, workshops, libraries, loading docks, hospitals, assembly lines, offices and nurseries. High quality durable powder coated finish on all models.



Hydraulic Scissor Lift Tables (two stage)

Complete with PU Wheels for which the Rear Wheels have hand locking devices

Product Code	342615	342630	342650
Model No.	TF15	TF30	TF50
Capacity (kg)	150	300	500
Min. Table Height A (mm)	220	295	295
Max. Table Height B (mm)	720	885	890
Table Length L (mm)	700	855	855
Table Width W (mm)	450	500	500
Table Thickness T (mm)	36	50	50
Castor Wheel	100 x 25	125 x 40	125 x 40
Foot Pedal Cycles to Max Height	<=28	<=39	<=27
Net Weight (kg)	49	77	81
Height of Handle from Ground H (mm)	935	985	985

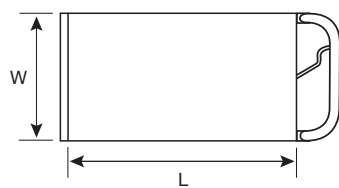
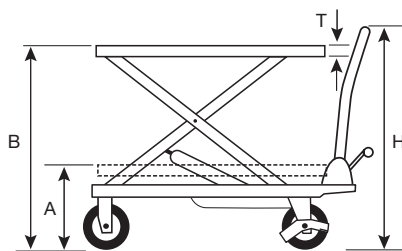

Materials Handling Equipment

Scissor Lift Tables & Hand Trolleys



Hydraulic Scissor Lift Tables (three stage)

Complete with PU Wheels for which the Rear Wheels have hand locking devices

Product Code	342635
Model No.	TF35
Capacity (kg)	350
Min. Table Height A (mm)	375
Max. Table Height B (mm)	1365
Table Length L (mm)	910
Table Width W (mm)	500
Table Thickness T (mm)	53
Castor Wheel	125 x 40
Foot Pedal Cycles to Max Height	<=53
Net Weight (kg)	136
Height of Handle from Ground H (mm)	965

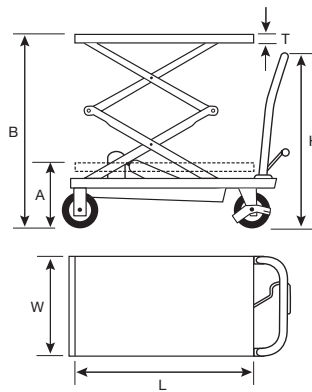

Steel Hand Platform Trolleys

Complete with PU Black Wheels

Product Code	342515	342525
Model No.	BPT015	BPT025
Capacity (kg)	150	250
Platform Length L (mm)	705	875
Platform Width W (mm)	440	570
Height H (mm)	860	860
Net Weight (kg)	12.5	18.6

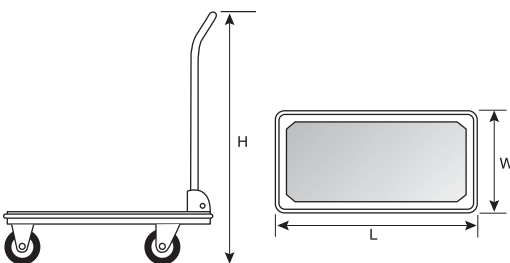

Materials Handling Equipment

Steel 2 Tier Hand Platform Trolleys



Complete with Nylon Black Wheels

Product Code	342513
Model No.	BSS22
Capacity (kg)	120
Platform Length L (mm)	475
Platform Width W (mm)	735
Height H (mm)	8650
Castor Wheel	100 x 35
Net Weight (kg)	15.6

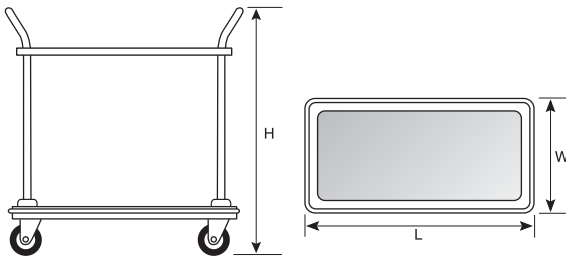

Steel 3 Tier Hand Platform Trolleys

Complete with Nylon Black Wheels

Product Code	342514
Model No.	BSS32
Capacity (kg)	120
Platform Length L (mm)	475
Platform Width W (mm)	735
Height H (mm)	8650
Castor Wheel	100 x 35
Net Weight (kg)	20.6

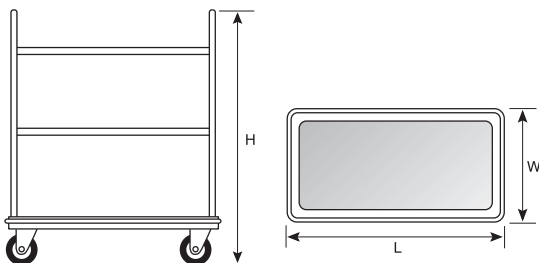

Materials Handling Equipment



Stainless Steel 2 Tier Hand Platform Trolleys

Complete with Nylon White Wheels

Product Code	342513S
Model No.	BT122S
Capacity (kg)	100
Platform Length L (mm)	480
Platform Width W (mm)	710
Height H (mm)	800
Castor Wheel	100 x 35
Net Weight (kg)	9.2

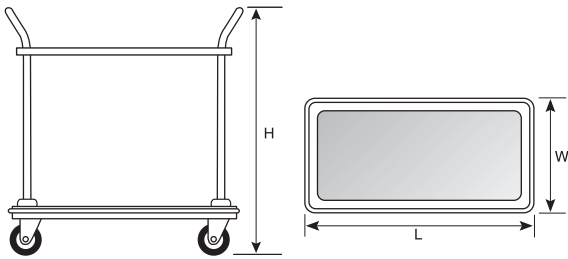

reliable ^ professional ^ achievable



2 Materials Handling

2014 edition

www.lifting.com.au



Forklift Attachments

Type SDLC1 Drum Lifter

Designed for standard 205 litre steel drums, the fully automatic clamping action enables safe and precise placement of drums without the operator having to leave the drivers seat. The arms will engage around the drum and lock under the rolling hoop when raised.

The SDL2 will handle either a single drum or two drums. Zinc plated finish.

Model	No. of Drums	SWL (kg)	Fork Pocket Centres (mm)	Fork Pocket Size (mm)	Load Centre (mm)	Unit Weight (kg)
SDL1	1	500	325	165 x 65	1340	62



Manufactured and Engineered Products

Type FJCS25 Fixed Jib Short – 2.5 Tonne

The FJS2.5 Fixed Jib allows for additional lifting height with the extension beam being raised above the fork pockets. The overall length when retracted is 1.3 metres, and when extended is 2 metres. Zinc plated finish.

- › Safe Working Load: 2500 kg Max
- › Fork Pocket Size: 185 mm x 65 mm
- › Fork Pocket Centres: 250 mm
- › Unit Weight: 100 kg

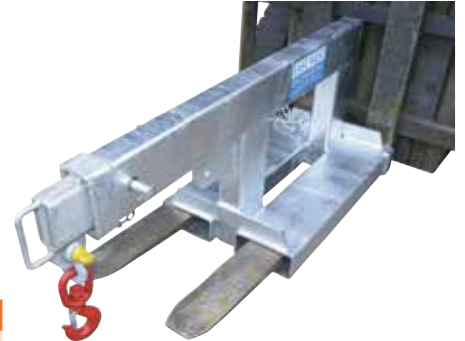

FJS2.5 Fixed Jib	Safe Working Load (SWL) per position			
POSITION	1	2	3	4
EXTENSION (mm)	790	1200	1580	1960
SWL (kg)	2500	1200	900	750

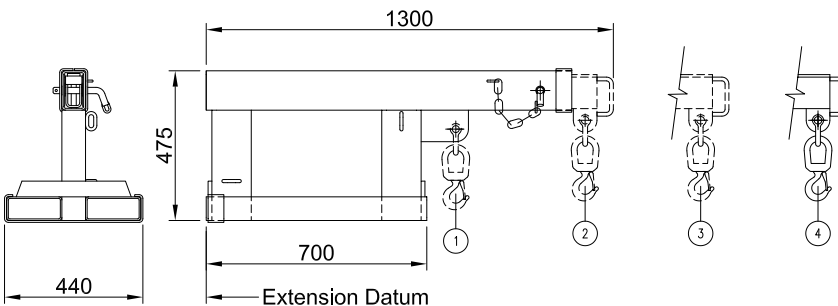

Type FJL2.5 Fixed Jib Long – 2.5 Tonne

The FJL2.5 has a 3.5 metre extension which allows for long reach lifts. The overall jib length when retracted is 2.1 metres. Zinc plated finish.

- › Safe Working Load: 2500 kg Max
- › Fork Pocket Size: 185 mm x 65 mm
- › Fork Pocket Centres: 250 mm
- › Unit Weight: 130 kg

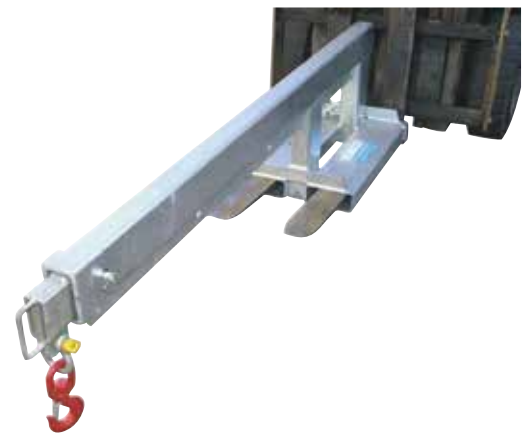

FJL2.5 Fixed Jib	Safe Working Load (SWL) per position							
POSITION	1	2	3	4	5	6	7	8
EXTENSION (mm)	950	1410	1870	2000	2380	2760	3140	3520
SWL (kg)	2500	2500	1900	1650	1250	650	380	240

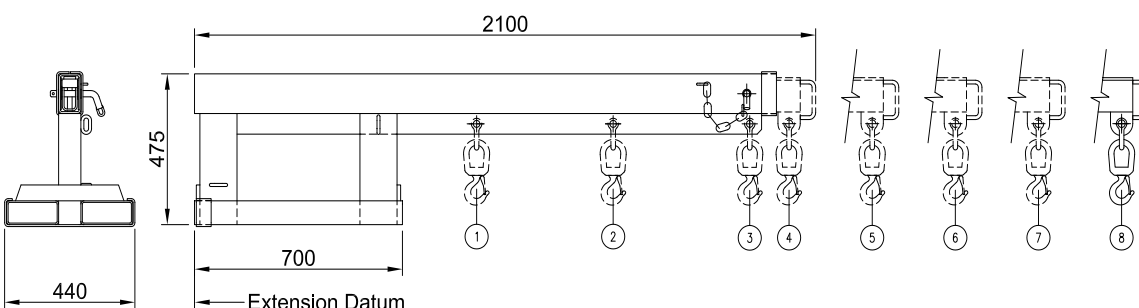

Manufactured and Engineered Products



Type FJCS45 Fixed Jib Short – 4.5 Tonne

The FJCS45 Fixed Jib is designed as an affordable general purpose jib able to manoeuvre in confined spaces, with a 1.9 metre reach when fully extended. The overall jib length when closed is 1.25 metres. Zinc plated finish.

- › Safe Working Load: 4500 kg Max
- › Fork Pocket Size: 185 mm x 65 mm
- › Fork Pocket Centres: 290 mm
- › Unit Weight: 95 kg



FJCS45 Fixed Jib	Safe Working Load (SWL) per position			
POSITION	1	2	3	4
EXTENSION (mm)	670	1165	1545	1925
SWL (kg)	4500	2900	1300	750

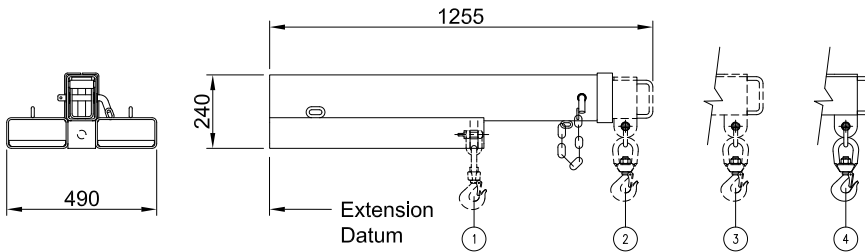

Type FJCL45 Fixed Jib Long – 4.5 Tonne

The FJCL45 Fixed Jib has a 3.5 metre reach when fully extended. Overall length when closed is 2.0 metres. Zinc plated finish.

- › Safe Working Load: 4500 kg Max
- › Fork Pocket Size: 185 mm x 65 mm
- › Fork Pocket Centres: 290 mm
- › Unit Weight: 140 kg



FJCL45 Fixed Jib	Safe Working Load (SWL) per position					
POSITION	1	2	3	4	5	6
EXTENSION (mm)	870	1945	2325	2705	3085	3465
SWL (kg)	4500	1300	750	560	380	200

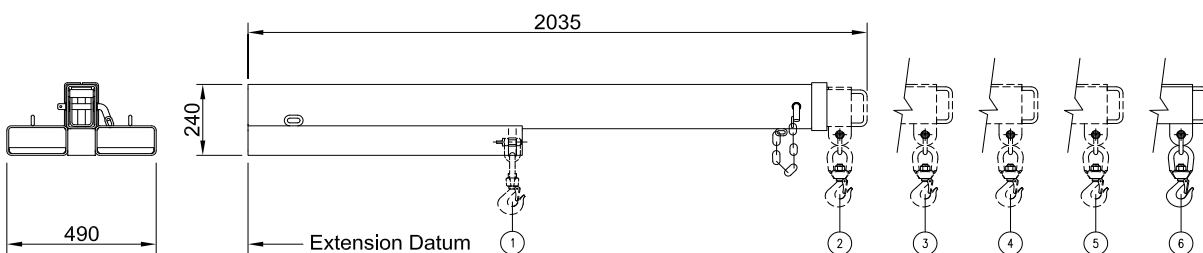

Manufactured and Engineered Products

Type FJCS50 Fixed Jib Short – 5 Tonne

The FJS5 Fixed Jib has a 1.96 metre reach when fully extended, and an overall length of 1.3 metres when retracted. The jib is secured to the forklift by a safety chain. Zinc plated finish.

- › Safe Working Load: 4750 kg Max
- › Fork Pocket Size: 185 mm x 75 mm
- › Fork Pocket Centres: 275 mm
- › Unit Weight: 130 kg



FJS5 Fixed Jib	Safe Working Load (SWL) per position			
POSITION	1	2	3	4
EXTENSION (mm)	780	1200	1580	1960
SWL (kg)	4750	2400	1800	1500

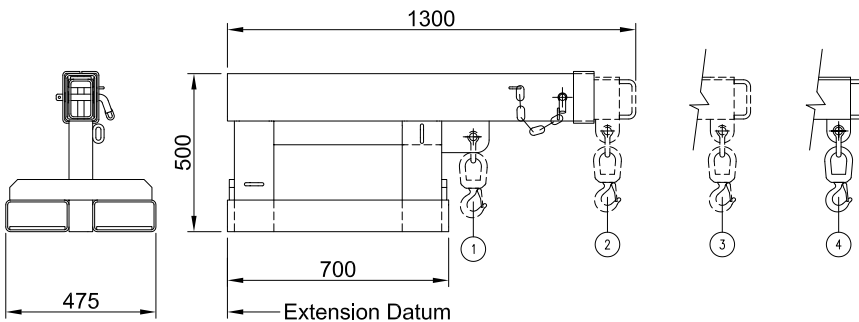

Type FJL5 Fixed Jib Long – 5 Tonne

The FJL5 Fixed Jib has a 3.5 metre reach when fully extended, and an overall jib length when retracted of 2.1 metres. Zinc plated finish.

- › Safe Working Load: 4750 kg Max
- › Fork Pocket Size: 185 mm x 75 mm
- › Fork Pocket Centres: 275 mm
- › Unit Weight: 170 kg

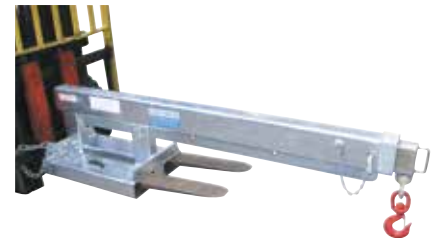

FJL5 Fixed Jib	Safe Working Load (SWL) per position							
POSITION	1	2	3	4	5	6	7	8
EXTENSION (mm)	935	1395	1855	2000	2380	2760	3140	3520
SWL (kg)	4750	4275	3800	3300	2500	1300	760	480

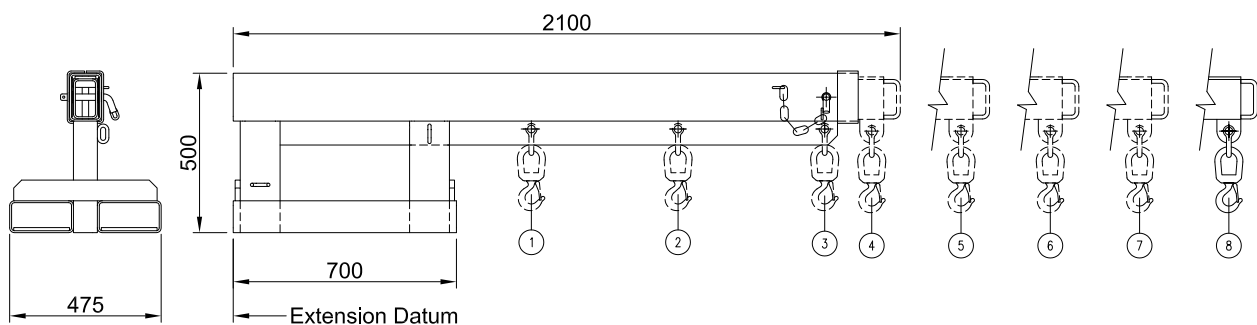

Manufactured and Engineered Products

Type TJCS25 Tilt Jib Short – 2.5 Tonne

The TJS2.5 Tilting Jib allows for additional height, compensating for length of the hook and slings when lifting. The jib boom can be set at 3 angled positions as well as level. Jib also offers 5 different hook positions, with a 2 metre maximum reach. Zinc plated finish.

- › Safe Working Load: 2500 kg Max
- › Fork Pocket Size: 185 mm x 65 mm
- › Fork Pocket Centres: 337 mm
- › Unit Weight: 130 kg

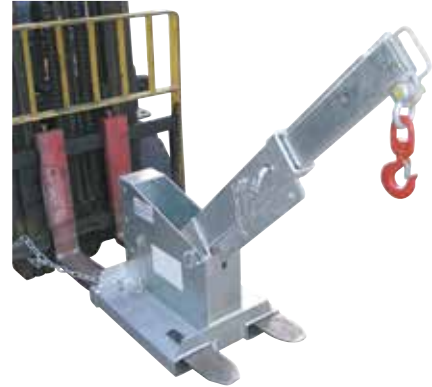

TJS2.5 Tilt Jib	Safe Working Load (SWL) per position				
POSITION	1	2	3	4	5
EXTENSION (mm)	825	1125	1260	1640	2020
SWL (kg)	2500	1800	1200	900	750

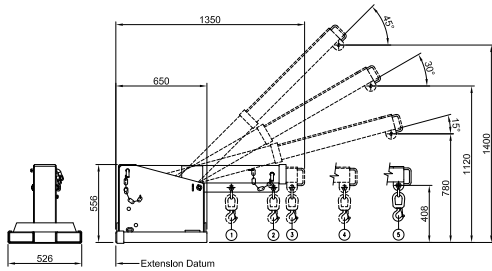

Type TJS5 Tilting Jib Short – 5 Tonne

The TJS5 Tilting Jib can be set at 3 angled positions as well as level. Jib also offers 5 different hook positions, with a 2 metre maximum reach. Zinc plated finish.

- › Safe Working Load: 4750 kg Max
- › Fork Pocket Size: 185 mm x 75 mm
- › Fork Pocket Centres: 370 mm
- › Unit Weight: 180 kg

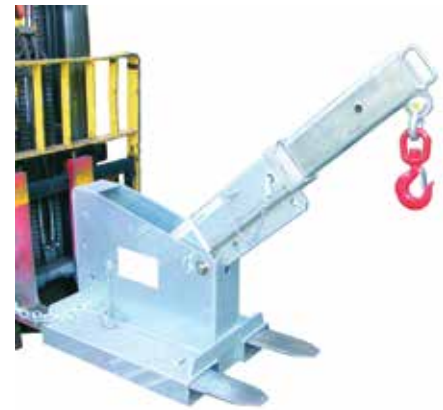

TJS2.5 Tilt Jib	Safe Working Load (SWL) per position				
POSITION	1	2	3	4	5
EXTENSION (mm)	825	1125	1260	1640	2020
SWL (kg)	2500	1800	1200	900	750

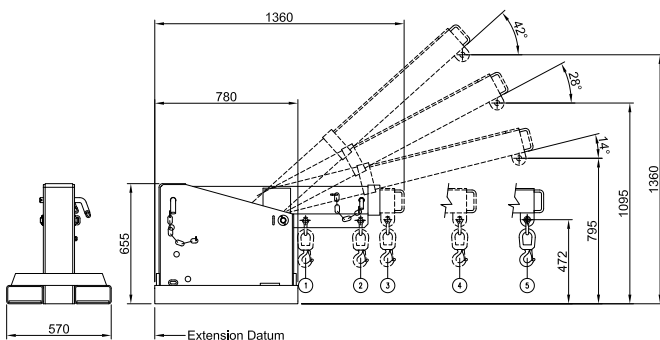

Manufactured and Engineered Products



Type SJ2 Forklift Slip-On Jib

Designed as a simple slip-on jib attachment with two hook positions 500mm apart. Both hook positions have an SWL of 2000kg. This Jib attachment is held to the forklift by a safety chain and comes complete with a safety swivel hook. Available in either galvanised or painted enamel finishes.

Features

- › Safe Working Load (SWL) 2000kg
- › Unit Weight 45kg
- › Load Centre 1000mm
- › Pocket Size 165 x 65
- › Pocket Centres 275 mm
- › Horizontal C of G 600mm
- › Vertical C of G 50mm

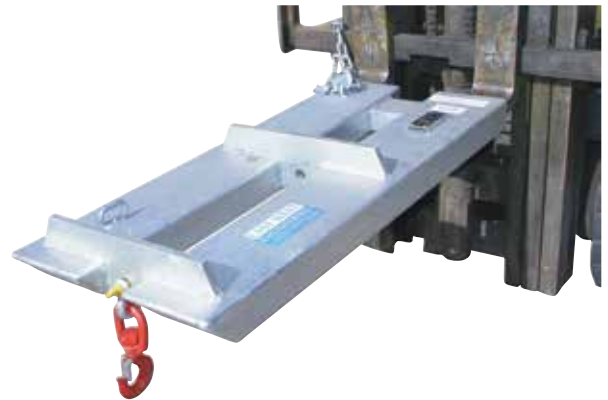

Type SJW Wide Pocket Jib

The SJW style jib is fitted with wide spaced fork pockets, and provides 2 lifting positions 550 mm apart. This is a simple slip on style jib, and is supplied with safety swivel hook. Zinc plated finish.

Specials Type	SWL Max. (kg)/550(mm)	SWL Max. (kg)/110(mm)	Fork Pocket size (mm)	Fork Pocket Centres (mm)	Unit weight (kg)
SJW 2.5	2500	1500	165 x 65	740	75
SJW 4.5	4500	3000	180 x 80	875	140
SJW 7	7000	5000	180 x 80	875	210
SJW 11	11,000	8000	230 x 110	875	260

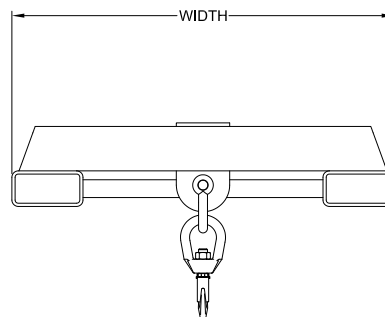
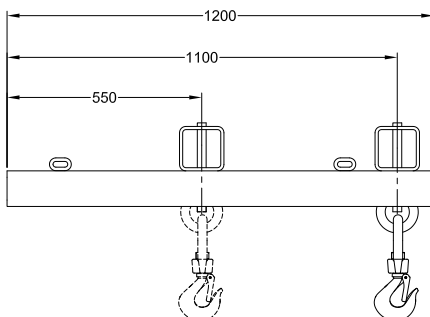
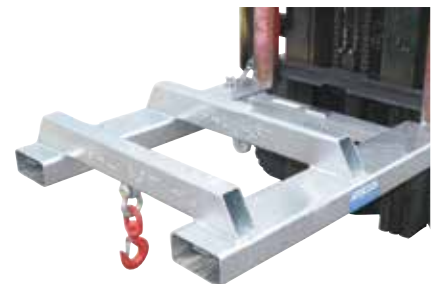

Manufactured and Engineered Products

Type WP-N Work Platform

The WP-N Work Platform has been designed for forklift use to safely carry out tasks of "short duration" and "occasional usage" such as maintenance or stocktake. Manufactured strictly in accordance with Australian Standard AS 2359.1, the type WP-N Work Platform is suitable for a maximum of two people. Supplied with slipper locking pins and 2 harness anchor rings.

Unit is supplied standard as a "Flatpack" (1230 x 1150 x 200mm), or may be fully assembled upon request. Zinc plate finish

- > Safe Working Load: 250 kg
- > Load Centre: 600 mm
- > Unit Weight: 110 kg
- > Fork Pocket Size: 160 mm x 60 mm
- > Fork Pocket Centres: 640 mm

PLEASE NOTE: The use of a WP-N Work Platform on a forklift truck should not be considered if the capacity of that forklift is less than 1800 kg for a counterbalanced type or 1080 kg for a straddle type forklift.

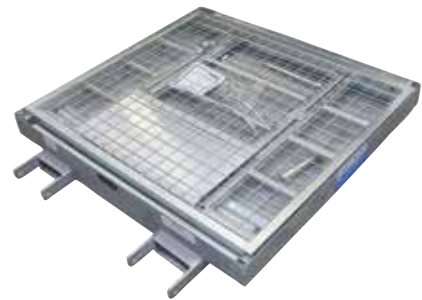

Type WP-GC Goods Cage

The WP-GC forklift goods cage is suitable for storage and transport of furniture and whitegoods, and is ideal for the transportation of goods between ground and mezzanine levels. Enamel paint finish.

The WP-GC forklift goods cage is NOT designed or certified to convey personnel.

- > Safe Working Load: 1000 kg
- > Fork Pocket Size: 160 mm x 60 mm
- > Fork Pocket Centres: 644 mm

Type	Width (mm)	Depth (mm)	Height (mm)	Unit Weight (kg)
WP-GC 12	1200	1200	1000	150
WP-GC 18	1800	1200	1000	190

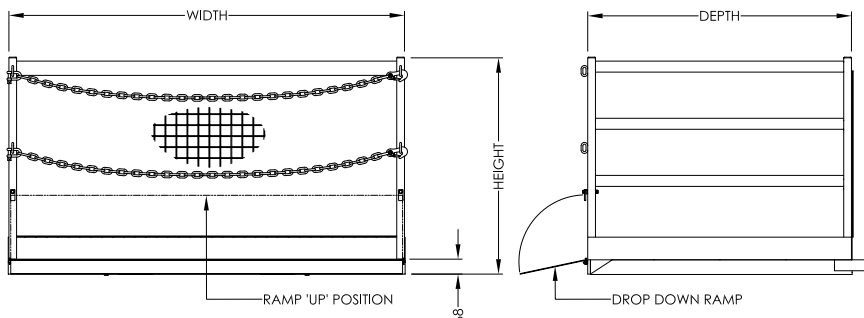

Manufactured and Engineered Products



Type FE Fork Extension Slippers

The FE Fork Extension Slippers extend the versatility of the fork truck. These slim profile slippers have been designed and manufactured in accordance with AS2359.15. In accordance with AS2359.15 slippers used for general usage should be no longer than 167% of the supporting tine's length.

If the slippers are longer than 167%, then the usage of those slippers shall be restricted to their specified application. • Made from high tensile grade steel

- › Zinc plated for corrosion protection (Type SL Painted)
- › High Safe Working Load (SWL) rating
- › Supplied with toggle locking pins
- › Fitted with rating plate
- › Supplied with instructions

Type	Length (mm)	To suit max tine size (mm)	Weight per pair (kg)	Rating per pair
FE1-16	1600	100 x 45	50	3000kg SWL at 600mm LC
FE1-18	1800	100 x 45	56	
FE1-21	2100	100 x 45	66	
FE1-24	2400	100 x 45	75	
FE2-16	1600	130 x 50	60	4500kg SWL at 600mm LC
FE2-18	1800	130 x 50	66	
FE2-21	2100	130 x 50	78	
FE2-24	2400	130 x 50	88	
FE3-16	1600	155 x 55	91	6500kg SWL at 600mm LC
FE3-18	1800	155 x 55	102	
FE3-21	2100	155 x 55	119	
FE3-24	2400	155 x 55	136	
FE3-30	3000	155 x 55	170	

Type	Length (mm)	To suit max tine size (mm)	Weight per pair (kg)	Rating per pair
FE4-18	1800	160 x 65	133	8500kg SWL at 600mm LC
FE4-21	2100	160 x 65	155	
FE4-24	2400	160 x 65	177	
FE4-30	3000	160 x 65	221	
SL5-18	1800	Custom built to suit	170	8000kg SWL at 600mm LC
SL5-21	2100		200	
SL5-24	2400		220	
SL5-30	3000		280	
SL6-21	2100		380	12000kg SWL at 600mm LC
SL6-24	2400		430	
SL6-30	3000		540	
SL6-35	3500		630	16000kg SWL at 600mm LC
SL7-24	2400		520	
SL7-30	3000		650	
SL7-35	3500	760		





BBP2000 Bulk Bag Lifter

A two prong Bulk Bag lifter for container loading. The Operator need not leave their seat to disengage the bag. Optional stand is available.

Features

- › Safe Working Load (SWL) 2000kg
- › Unit Weight 200kg
- › Load Centre 725mm
- › Height above Carriage 378mm
- › Prong Centres 800mm
- › Class 2 Mounting

(Also available with Class 3 Mounting)

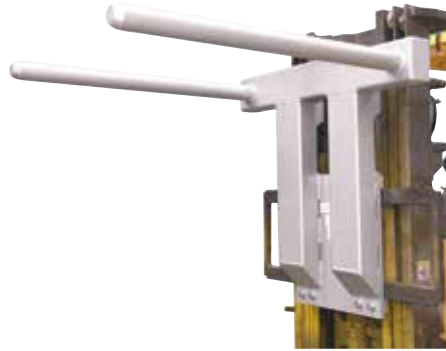

BJFL1 Slip-On Bulk Bag Jib

Designed with 4 lifting points to suit standard Bulk Bags. The Jib is fitted with four (4) safety swivel hooks.

Features

- › Pocket Size 165 x 65mm
- › Pocket Centres 640mm
- › Safe Working Load (SWL) 2000kg
- › Unit Weight 75kg
- › Load Centre 700mm
- › Hook Centres 900mm



Manufactured and Engineered Products

Type PHD 2200 Pallet Hook



The PHD 2200 pallet hook is a versatile unit which features adjustable body height and fork tine width positioning, which makes this unit ideal for the transport and construction industry. Load balancing is carried out by positioning the lifting ring to suit the centre of gravity of the load. Zinc plated finish.

- > Safe Working Load: 2200 kg
- > Load Centre: 600 mm
- > Unit Weight: 215 kg

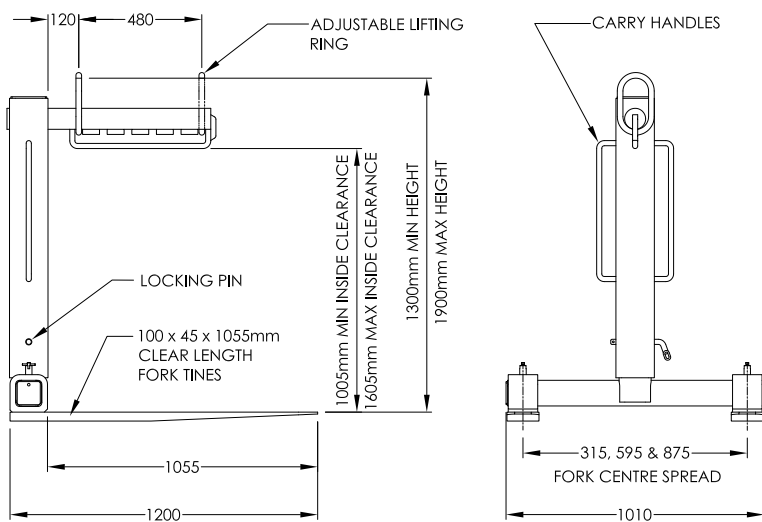



Work Cages

Note: All crane work platform cages we supply are designed and manufactured in accordance with AS1418.17, and are supplied with load test certificate, instruction manual, risk control measures and WorkCover registration. Fork pockets fitted for transport purposes only. Personnel cages are supplied with chains, safety harness anchor points, and are painted Safety Yellow enamel.

Type WP-C

Two person cage, with mesh roof.

Maximum capacity: 2 people

- > Safe Working Load: 250 kg
- > Unit Weight: 160 kg
- > Fork Pocket Size: 165 mm x 65 mm
- > Fork Pocket Centres: 775 mm

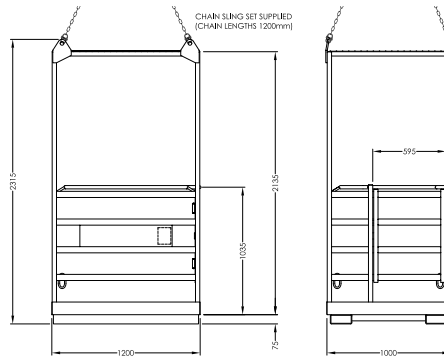

Type WP-C2

Four person cage, with mesh roof.

This Cage can also be manufactured to suit First Aid Rescue by fitting an outward opening gate. Please specify when ordering.

- > Maximum capacity: 4 people
- > Safe Working Load: 500 kg
- > Unit Weight: 400 kg
- > Fork Pocket Size: 245 mm x 65 mm
- > Fork Pocket Centres: 950 mm

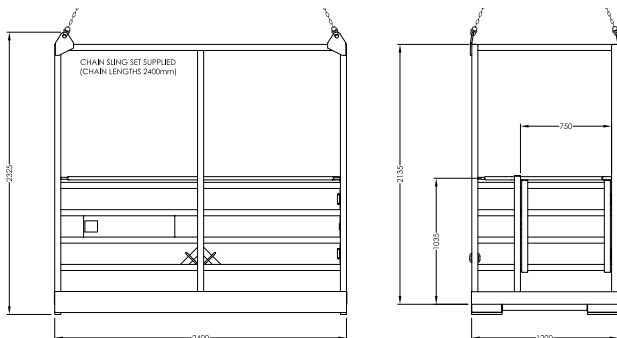

Manufactured and Engineered Products



Type WP-CII

Two person cage, no roof

- › Maximum capacity: 2 people
- › Safe Working Load: 250 kg
- › Unit Weight: 160 kg
- › Fork Pocket Size: 165 mm x 65 mm
- › Fork Pocket Centres: 775 mm

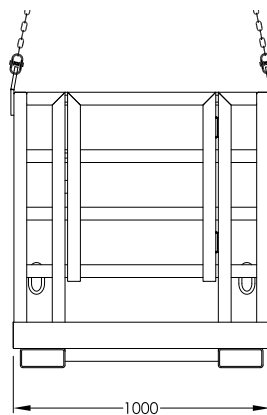
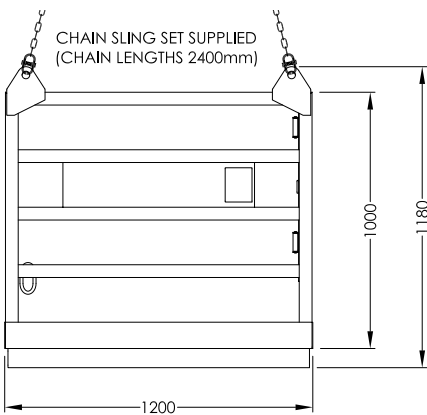

Type WP-C4

One person cage, without roof

- › Maximum capacity: 1 person
- › Safe Working Load: 250 kg
- › Unit Weight: 120 kg
- › Fork Pocket Size: 165 mm x 65

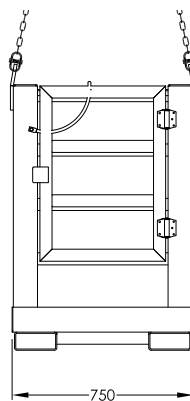
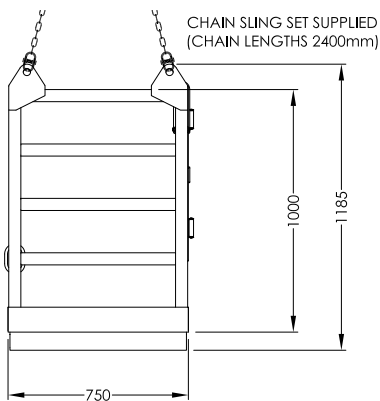



Type WP-C8

Single person cage, fitted with mesh roof

- > Maximum capacity: 1 person
- > Safe Working Load: 250 kg
- > Unit Weight: 150 kg
- > Fork Pocket Size: 165 mm x 65 mm
- > Fork Pocket Centres: 555 mm

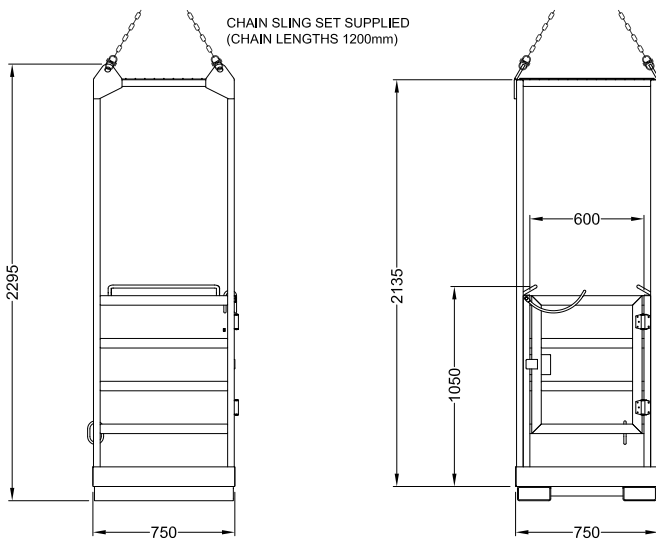

Type WP-C6

6 person cage, fitted with full mesh infill. The front mesh panel above handrail height is removable for working access.

- > Maximum Capacity: 6 people
- > Safe Working Load: 900 kg
- > Unit Weight: 700 kg

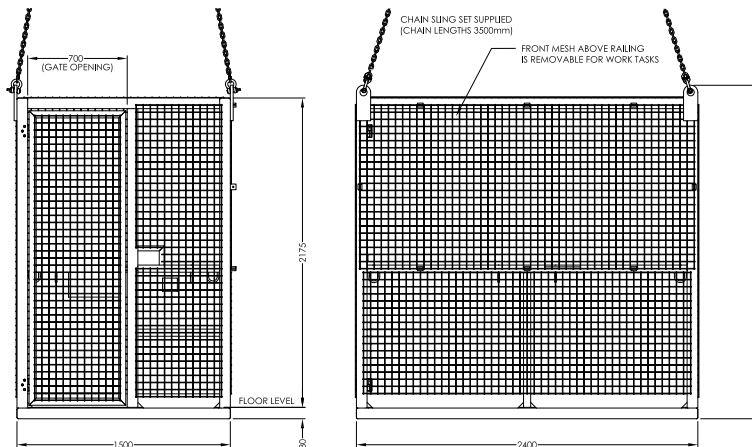

Manufactured and Engineered Products



Storage Cages

Type CSPN-01 Goods Cage

Safely convey loose or palletised goods using either forklift or crane. Full width gate allows for 1200mm square pallets to be placed inside. Fitted with crane lifting lugs, fork stirrups and interlocking feet, this versatile cage can also be safely stacked. Zinc plated finish.

- > Safe Working Load: 1000 kg
- > Unit Weight: 175 kg

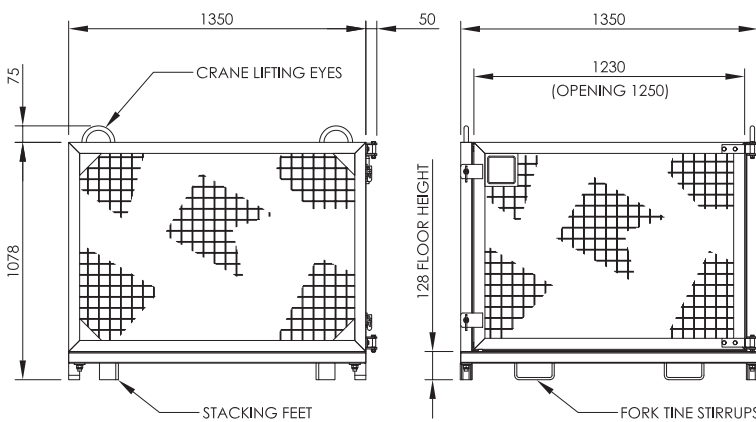

Beaver Oxygen/Acetylene Gas Bottle Trolley

Designed for use as trolley, lifting frame or use with a forklift.

Product Code	Capacity (kg)	H (mm)	B (mm)	W (mm)	C (mm)	A (mm)	D (mm)	Weight (kg)	UOM
263200T	200	1600	1280	635	394	644	100	76	Each

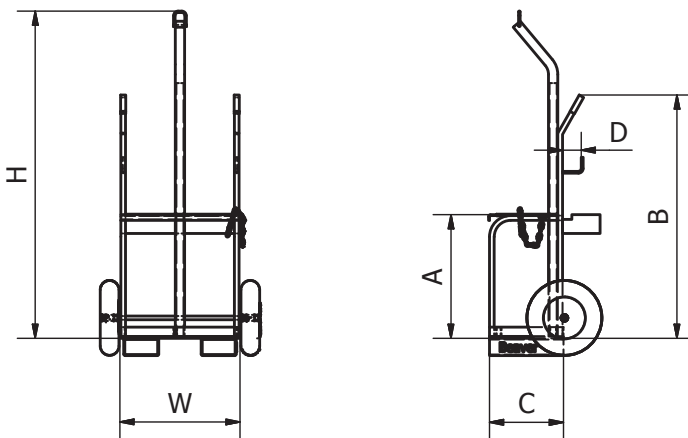

Type GB-CMA Storage Cage

Secure gas cylinder storage cage, suitable for environments such as building sites and mines. Cage is fitted with crane lifting lugs, and fork pockets underneath. Cage is fitted with a lockable door, and has a full metal roof providing weather protection. A securing load binder prevents cylinder movement during transport. Zinc plated finish.

- > Safe Working Load: 750 kg
- > Unit Weight: 180 kg
- > Fork Pocket Size: 165 mm x 65 mm
- > Fork Pocket Centres: 805 mm

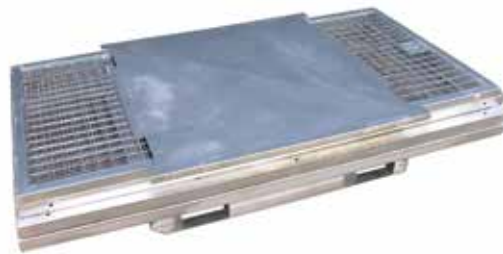

Flatpack version (Type GB-CMF)



Type GB-SC Gas Bottle Storage Cage

The GB-SC gas cylinder cage is designed for storage and transportation of gas cylinders either by forklift or by overhead crane. The cage is fitted with 4 crane lugs and fork access underneath. This stackable cage is fitted with double 270 degree opening gates for easy access, and is supplied with load binder to securely fasten cylinders. The cage can be supplied fully assembled or as a flatpack for on-site assembly. Zinc plated finish.

- > Safe Working Load: 1000 kg
- > Unit weight: 170 kg

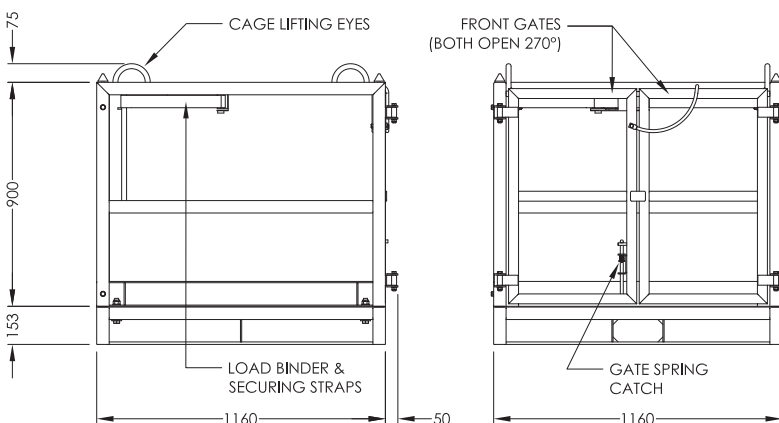

Manufactured and Engineered Products



Type MMC-01 Mesh Cage

A stackable transport and storage cage, ideal for production, warehousing and component storage applications. Easily collapsible for space saving during transport, the MMC-01 is assembled without any tools in seconds. Cage is fitted with a drop down access gate allowing easy access to the base, even when stacked.

The MMC-01 cage can be transported by forklift or pallet trolley, and can be stacked 2 high when fully loaded, making this cage suitable for racking or stand alone applications. Front and rear panels are removable.

- › Load Capacity: 1000 kg
- › Unit Weight: 94 kg
- › Collapsed Height: 248 mm
- › Powder coated frame / zinc plated insert panels.

Internal Width (mm)	Internal Depth (mm)	Internal Height (mm)	Overall Width (mm)	Overall Depth (mm)	Overall Height (mm)
1080	1080	740	1170	1170	920

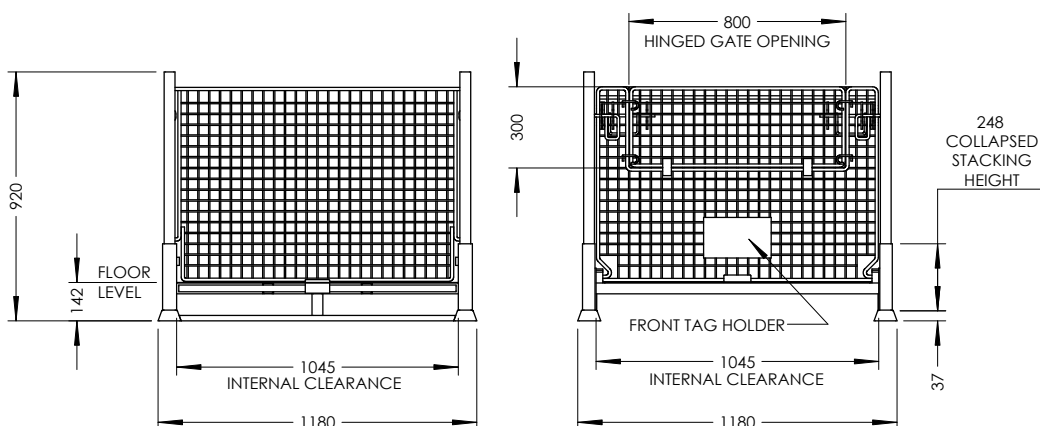

Telescopic Combination Lifting Beam/Spreader Bars

Capacity: 6 tonne to 50 tonne

The Maxirig Telescopic Spreader Beam is designed for a variety heavy lifting applications. Designed to function as a spreader bar in the 60°, 90° and 120° positions, it can also be used as a lifting beam from the centre lift (lug) position.

The product is supplied with a proof load test certificate, MPI welding inspection report and certificate of conformance to Australian Standards (AS4991).

Prior to conducting any operations with this device, a lift study must be undertaken noting the capacity of the device in its various configurations.

Shackles To Suit:- Please use Grade S Safety Bow Shackles.



Note: For further technical information including Working Load Limits at various angles, approximate sling leg lengths and headroom, please contact Robertsons for a detailed data sheet.

Product Code	WLL as Spreader at 60° (End Lift) (t)	WLL as Lifting Beam (Centre Lift) (t)	Span Width		TARE (kg)	Top Lifting Lugs Size (Grade S Safety Bow Shackle) (t)	Lower Load Lugs (Grade S Safety Bow Shackle) (t)	Centre Lug (Grade S Safety Bow Shackle) (t)
			Min (m)	Max (m)				
TSB1015	1.5	N/A	1.8	3.0	25	1.5	1.5	N/A
TSB1063	6.0	N/A	2.0	3.0	50	4.7	4.7	N/A
TSB1065	6.0	N/A	3.0	5.0	105	4.7	4.7	N/A
TSB1103	10.0	1.8-2.75	2.3	3.5	100	8.5	6.5	3.2
TSB1106	10.0	N/A	4.0	6.0	160	8.5	6.5	N/A
TSB1204	20.0	2.3-3.5	2.7	4.0	150	17.0	12.0	4.7
TSB1206	20.0	1.3-2.1	4.0	6.0	215	17.0	12.0	4.75
TSB1304	30.0	2.2-3.1	2.8	4.0	200	25.0	17.0	4.7
TSB1306	30.0	1.4-2.2	4.0	6.0	260	25.0	17.0	4.7
TSB1504	50.0	3.75-6	2.8	4.0	260	35.0	25.0	6.5
TSB1506	50.0	2.6-4.2	4.0	6.0	360	35.0	25.0	6.5
TSB1806	80.0	5.0	4.0	6.0	605	55.0	55.0	6.5

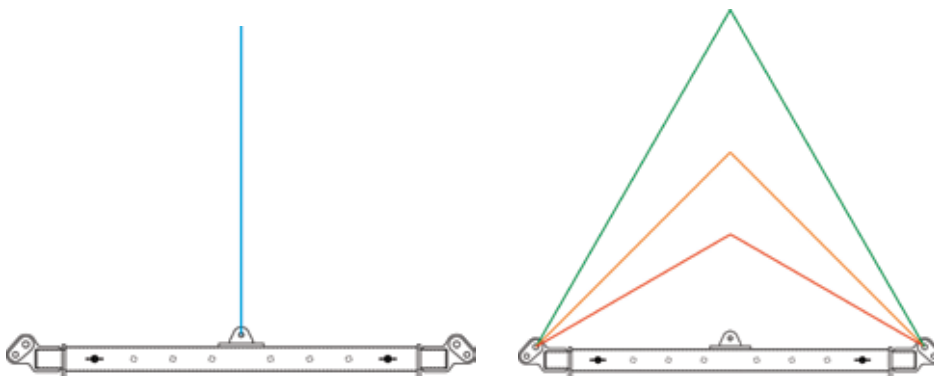

Note: For approximate sling lengths and headroom, please refer to the relevant product data sheet.

Manufactured and Engineered Products

Maxirig

Maxibar Modular Spreader Bars/Systems

Capacity: 4 tonne to 145 tonne

Meets: Australian Standard AS4991 - 2004

Maxibar Modular Spreader Bars are designed for heavy lifting applications including major construction projects. Each bar features heavy duty fittings and operates in the 60°, 90° and 120° positions..

Each modular spreader bar is supplied with a proof load test certificate, MPI welding inspection report and certificate of conformance to Australian Standards (AS4991).

Prior to conducting any operations with this device, a lift study must be undertaken noting the capacity and tare weights of the device in its various configurations.



Note: For further technical information including Working Load Limits at various angles, approximate sling leg lengths and headroom, please contact Robertsons for a detailed data sheet.

Product Code	WLL as Spreader at 60 ° (t)	Span Width		Max Span Width (m)	TARE (kg)	Top Lifting Lugs (Shackle size) (t)	Lower Load Lugs (Shackle size) (t)
		Min	Max				
Maxibar4	4.0	0.5	1.5	1.5	33	3.2	2.0
Maxibar 8	8.0	0.5	2.5	2.5	55	6.5	4.7
Maxibar 15	17.0	1.0	4.0	4.0	125	12.0	8.5
Maxibar 30	34.0	1.5	4.5	6.0	291	25.0	17.0
Maxibar 40	43.0	1.5	6.5	8.0	468	25.0	25.0
Maxibar 60	60.0	1.5	7.5	11.0	941	35.0	35.0
Maxibar 80	85.0	2.0	7.5	12.0	1220	55.0	55.0
Maxibar100	110.0	2.0	12.0	10.5	1895	85.0	55.0
Maxibar120	130.0	2.0	12.0	16.0	2195	85.0	85.0
Maxibar145	145.0	2.0	13.5	20.0	3900k	85.0	85.0

*Using the maximum span width of each Maxibar will reduce the WLL on all models except the Maxibar 4, 8 and 15. Please refer to detailed data sheets available from your local Robertsons branch, for further information.

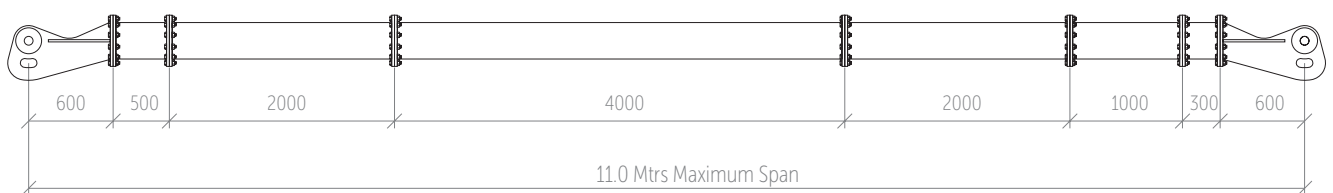

Example of a 60T Modular Spreader Bar showing length of each module within the beam.

Manufactured and Engineered Products



Maxilug Spreader Bar End Caps

Maxilugs allow users to create their own custom length, medium-lift spreader bar utilising these heavy duty end units.

Manufactured to AS4991-2004, Maxilugs are proof load tested and MPI Weld inspected.



Maxilug 25

Capacity	Tare Weight	Lifting Lugs (top) suit	Load Lugs (lower) suit	Intermediate Pipe
25 tonne at 60°/20 tonne at 90°	65kg each/130kg per pair (excludes pipe or rigging)	17 tonne grade 'S' safety bow shackle	13 tonne grade 'S' safety bow shackle	273.1mm OD x 6.4mm wall C350LO (42.1kg/m)

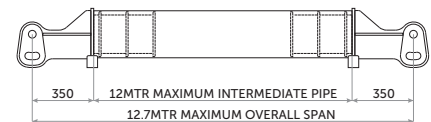

Maxilug 50

Capacity	Tare Weight	Lifting Lugs (top) suit	Load Lugs (lower) suit	Intermediate Pipe
50 tonne at 60°/30 tonne at 90°	110kg each/220kg per pair (excludes pipe or rigging)	35 tonne grade 'S' safety bow shackle	35 tonne grade 'S' safety bow shackle	273.1mm OD x 6.4mm wall C350LO (42.1kg/m)

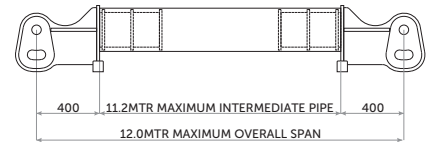

Maxilug 80

Capacity	Tare Weight	Lifting Lugs (top) suit	Load Lugs (lower) suit	Intermediate Pipe
80 tonne at 60°/35 tonne at 90°	175kg each/350kg per pair (excludes pipe or rigging)	55 tonne grade 'S' safety bow shackle	55 tonne grade 'S' safety bow shackle	323.9mm OD x 9.53mm wall C350LO (73.9kg/m)

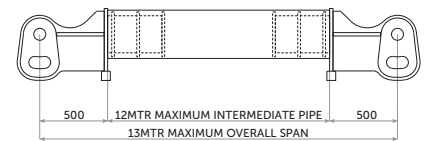

Maxibar 145

Capacity	Tare Weight	Lifting Lugs (top) suit	Load Lugs (lower) suit	Intermediate Pipe
145 tonne at 60°/80 tonne at 90°	210kg each/420kg per pair (excludes pipe or rigging)	85 tonne grade 'S' safety bow shackle	85 tonne grade 'S' safety bow shackle	355.6mm OD x 9.53mm wall C350LO (81.1kg/m)

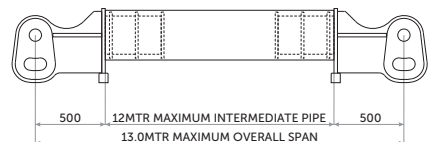

Maxibar 250

Capacity	Tare Weight	Lifting Lugs (top) suit	Load Lugs (lower) suit	Intermediate Pipe
250 tonne at 60°/160 tonne at 90°	600kg each/1200kg per pair (excludes pipe or rigging)	150 tonne grade 'S' safety bow shackle	150 tonne grade 'S' safety bow shackle	457mm OD x 12.7mm wall C350LO (139kg/m)

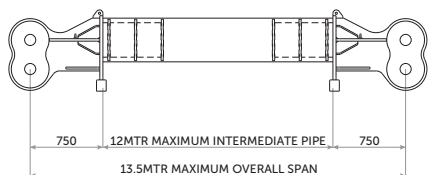

Maxibar 400

Capacity	Tare Weight	Lifting Lugs (top) suit	Load Lugs (lower) suit	Intermediate Pipe
400 tonne at 60°/230 tonne at 90°	0.80t each/1.6t per pair (excludes pipe or rigging)	250 tonne safety bow shackle	250 Tonne safety bow shackle	508mm OD x 12.7mm wall C350LO (155kg/m)

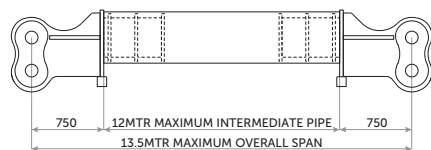



BRISBANE SOUTH	4 Burchill St Loganholme, Qld 4129	P 07 3801 0811	E Sales.brisbane@jlr.com.au
BRISBANE NORTH	5 Johnstone Rd, Brendale, Qld 4500	P 07 3881 1445	E Sales.brendale@jlr.com.au
GOLD COAST	39 Dover Dve, Burleigh Heads, Qld 4220	P 07 5535 8277	E Sales.goldcoast@jlr.com.au
TOOWOOMBA	345 Taylor St, Toowoomba, Qld 4350	P 07 4634 6566	E Sales.toowoomba@jlr.com.au
MACKAY	179 Boundary Rd, Paget, Qld 4740	P 07 4952 5520	E Sales.mackay@jlr.com.au
GLADSTONE	4 Tranberg St, Gladstone, Qld 4680	P 07 4972 6511	E Sales.gladstone@jlr.com.au
SYDNEY	50 Skarratt St, Silverwater, NSW 2128	P 02 9748 3044	E Sales.silverwater@jlr.com.au
NEWCASTLE	33 Firebrick Dve, Thornton NSW 2322	P 02 4966 8622	E Sales.thornton@jlr.com.au
MUSWELLBROOK	49 Thomas Mitchell Dve, M'brook NSW	P 02 6541 5100	E Sales.muswellbrook@jlr.com.au
MELBOURNE	4/28-30 Little Boundary Rd, Laverton Nth, Vic	P 03 9315 1520	E Sales.melbourne@jlr.com.au
DANDENONG	28 Swift Way, Dandenong South, Vic 3175	P 03 9768 3244	E Sales.dandenong@jlr.com.au
PERTH	16-18 Kewdale Rd, Welshpool, WA 6106	P 08 9451 1522	E Sales.perth@jlr.com.au

www.lifting.com.au